



PROJECT MANAGEMENT INFORMATION SYSTEMS

**Guidelines for Planning,
Implementing, and
Managing a DME Project
Information System**

Rodolfo Siles, 2004



“Knowledge about how to treat such a simple ailment as diarrhea has existed for centuries but millions of children continue to die from it because their parents do not know how to save them....Fighting poverty requires a global strategy to share knowledge systematically and energetically and to ensure that people who need that knowledge get it on time”.
The World Bank

Table of Contents

1. INTRODUCTION.....	6
1.1 Preface	6
1.2 Guidelines Overview	9
1.3 Objective of the Guidelines	9
1.4 Background	10
1.5 Systematize Before you Automatize	12
1.6 Audience	13
1.7 Structure of the Guidelines	13
1.8 Keep it Simple!	14
2. DEFINING DME-IS	16
2.1 Definition of Project DME-IS	16
2.2 Review of the Project Cycle in DME	17
2.3 The CARE International Project DME Standards.....	19
2.4 Characteristics of DME-IS	19
2.5 DME-IS levels of Technology	20
2.6 Identifying a project's MIS technology needs	26
2.7 From Data to Information to Knowledge and Wisdom ..	29
3. FUNDAMENTALS OF DME-IS	33
3.1 The Core Processes of DME-IS.....	33
3.2 Managing the Information Process	35
3.3 Depth of detail in DME-IS (keep it simple).....	37
3.4 Log Frame and DME-IS	37
3.5 DME-IS at the Project Level	44
3.6 DME-IS at the Country or Program Level.....	44
4. COMPONENTS OF DME-IS	51
4.1 What we do	53
4.2 For Whom we do it	62
4.3 By Whom we do it	65
4.4 With whom we do it	71
4.5 At what cost?.....	72
4.6 Where we do it?	77
4.7 How effective we are.....	80
5. INFORMATION ENVIROMENT	83
5.1 Information Economics.....	84
5.2 Information Dimensions	85
5.3 Information Logistics.....	87

5.4	Information Staff.....	88
5.5	Information Standards and Principles	90
5.6	Information Strategy	92
5.7	Information Politics.....	93
5.8	Information Culture	94
5.9	Information Governance.....	96
5.10	Information Architecture.....	98
6.	INFORMATION MANAGEMENT	106
6.1	Defining Information Needs	108
6.2	Locating Information Sources.....	115
6.3	Selecting Information needed to collect	120
6.4	Collecting and gathering the information.....	124
6.5	Organizing and storing Information	132
6.6	Reporting and Sharing Information	140
6.7	Using the Information	146
6.8	Evaluating the Process and the Information.....	149
6.9	Improving the Information Process	153
7.	INFORMATION PLAN	157
7.1	Introduction.....	159
7.2	Information Requirements	160
7.3	Information Collection.....	161
7.4	Information Analysis	168
7.5	Reporting Information.....	170
7.6	Historical Information.....	171
7.7	Access to Information	172
7.8	Personnel	173
7.9	Technology.....	175
7.10	Internal Controls	178
7.11	Implementation Strategies.....	179
7.12	Monitoring the DME-IS	180
7.13	Evaluating and Improving DME-IS.....	184
7.14	Information Audits.....	185
	FIGURE INDEX.....	188



Chapter 1

Introduction

1

1. INTRODUCTION

“One of the great mistakes that organizations make is to value the technology over the process. This can lead to organizations investing heavily in systems that go beyond their needs and then failing to make use of them effectively. Information technology, on its own, will not create better information systems that enable organizations to function more effectively. Organizational cultures need to be changed so that the wider processes information management becomes a priority.”¹

1.1 Preface

CARE is a rich organization in information resources, our program activities produce every day a wealth of information on every aspect of our work. We are by essence an organization that creates vast amounts of data, information and knowledge. We are an organization rich in methodologies, practices, implementation strategies, work methods and experiences. But at the same time we are a poor organization in terms of managing these vast wealth of resources.

Every day CARE projects discover and apply new methods, practices and experiences in their work. All this knowledge stays isolated from the rest of the organization and only in few opportunities or events we have a chance to share this new knowledge among ourselves, not as result of a plan but as a result of individual initiatives. This lack of proper sharing results in a duplication of efforts and costs that should be avoided. For example; a project in Ecuador needs to know more about nutrition methodologies for premature infants, a project in Ethiopia has invested and implemented a methodology to solve the very same problem. How can the organization connect these two projects?, How can we connect the knowledge seeker and the knowledge holder and establish means for both to share and learn from each other?

¹ Paul Currion, *Humanitarian Community Information Centre*

CARE Projects are learning-intensive organizational forms, but very little knowledge remains in the organization at the end of a project. The borders between time bound projects and the permanent organization are strong barriers for sharing knowledge and experiences gained in projects.

What do we mean by information management? Information Management means identifying what information is needed, who has the information, how we can capture and store the information, and finding the best method for its distribution and use. Information Management involves seeing information as a key resource which is available to the organization and one which is used and reused to met our objectives.

We need to treat information as a strategic resource and manage it accordingly, the same way we manage people, financial and physical resources. As an organization we need to improve the way we manage our information to bring the right information, to the right people at the right time. It is through information management that we can improve our decision making process, learn and create new knowledge.

Information management is the process of creating, identifying, collecting, organizing, sharing, adapting and using the information on practices that have produced outstanding results in other situations and that could be adapted to another situation. If we define knowledge as information in action then when information is used and applied to a context is when new knowledge is created. Knowledge resides in people's experiences, this "intellectual capital" is one of CARE's mission critical assets. Information on practices in the field and information on current methodologies, solutions and approaches need to reach an ever wider audience that in many cases lays outside CARE's organizational boundaries.

Knowledge Management is about the organizational incentives, rewards, structures and behaviors required for staff to share, learn and use the tacit subjective insights, intuitions, and experiences. Knowledge cannot be managed as a process like information. Knowledge resides in people's head, is subjective and requires trust. Knowledge is richer and broader than data and information, it is a fluid mix of experiences, values, contextual information, and insight that provides a framework to evaluate

and incorporate new experiences and information. It originates and derives from minds at work. Knowledge exists within people, its intuitive and hard to capture in words or understand in logical terms. Knowledge derives from information, as information derives from data. Information becomes knowledge when people do the work and realize an action that generates experiences, and should be evaluated by the decisions or actions to which it leads.

A key element is the recognition that creating new knowledge is not just a matter of "processing" information. It depends on exploiting the explicit and implicit information which contains insights, intuitions and experiences of individuals and making them available for testing and use by the organization as a whole. For this to happen we need to adopt a holistic approach to information management, an approach that takes in consideration organizational culture and politics, information economics and processes, information standards and policies, information strategies and governance.

All of above conform an information ecosystem that puts people at the center and technology as an enabler. It has to do more with managing human behaviors than managing technology.

For projects to be successful in information management, a careful analysis is required on how the elements of the information environment need to be treated. It is not enough to see information as a product, we need to treat information from all its dimensions that are affected by the organization and avoid "tunnel vision" solutions, specially an understanding of the critical social networks in which information and knowledge are always a part of.

The management of our information assets is essential to the long-term survival of our organization. In the knowledge era, organizations will be measured by how they are able to tap this vast resource, our organization's ability to learn, adapt, and change will become a core competency.

We also need to develop an understanding that knowledge resides in a complex and ever changing environment, this ever changing environment makes it more compelling to improve the way we capture, share and use information, so that information can get to those who need it, when they need it, so they can

take the correct actions and decision that lead to the creation of new knowledge.

With information management projects will be able to improve processes for how they define, locate, collect, store, analyze, share and use information. Is information what we turn into knowledge by the actions and experience we gain in the field, in the projects and in our interactions with all stakeholders, and managing this process should be our objective. Information should be managed within the context where it matters the most, where value is created to help us achieve our mission.

Good development depends upon good information.

1.2 Guidelines Overview

The guidelines presented here were developed to help project managers gain a common understanding of the process to manage a project DME information system.

The management of project information is a key element and a critical responsibility of a project office, and therefore the information it generates should be managed accordingly.

These guidelines focuses on how an information system can help project managers use information for decision making, decisions that will lead to improvements in the project operations.

1.3 Objective of the Guidelines

The goal of the DME-IS is to provide managers and key project stakeholders with the right information so that decisions can be made to improve the outputs and the impact of project interventions.

Project monitoring and evaluation systems at country office operations serve three principal purposes:

1. To provide information for decision-making and improve project management
2. To demonstrate results through project evaluation.
3. To empower communities and other project stakeholders.
4. To increase opportunities to learn from best practices.

We hope that with better information management the right information can be made available to the right people at the right time.



Project Stakeholders are individuals and organizations who are actively involved in the project, or whose interests may be positively or negatively affected as a result of project execution or successful project completion.

1.4 Background

1.4.1 What is DME-IS ?

Project DME Information Systems can be defined as an integrated set of mutually supporting tools, processes and methods for managing project information. Applied in a consistent way to support the decision making and information needs of the project stakeholders and CARE



An integrated set of mutually supporting tools, processes and methods for information management, that are regularly applied in a consistent way to efficiently and effectively address CARE and other stakeholders' needs for project monitoring information.

DME-IS is the management of information systems (MIS) as they pertain to the activities to monitor project activities, outputs, results and goals. It is defined in terms of *systems* for processing and sharing information and knowledge, and not confined only to software and hardware.

1.4.2 The Current Problems with Project Information Systems

We hope these guidelines will help solve many of the current problems facing projects with information management, problems that for the past years have been a source of complains from information users as well as information providers.

Isolated systems; one of the consistent and recurring messages is that projects are creating and using systems that are too narrow in scope and limited to track project activities and not project outcomes. These systems are designed to manage the information needs of a specific project and as a result efforts from the country office to consolidate information from all these systems is almost impossible.

Drowning on data and starving of information; some project systems focus too much on collecting, organizing and reporting data giving little time to critically analyze the information and make sound decisions.

High expectations; people involved in the collection of data receive high expectations as to the value of the data requested from them, only to never see the information come back. In these cases information tends to flow in one direction.

Low priorities in information management; project MIS is often relegated to outside consultants or given to staff with inadequate skills. It is often that these responsibilities are not well assigned and accountability becomes diffused.

Technology myopia; expectations that technology will be the final solution has led to an inappropriate focus that resulted in spending more time in managing the technology than managing the information.

Systems disconnected from the logframe; project MIS are developed but only respond to the immediate needs of the project, reporting on project activities without creating the connections with the desired objectives; systems designed to monitor progress but do not show how this progress relates with what the project has set out to achieve.

Reports for reporting sake; reports from projects are not connected with the decision process of the country office, reports stay at manager's desks and no relevant information is extracted from them.

No standard MIS process; the lack of a standard process has led to the development of many systems each with its own processes, all disconnected from each other.

No common Project Management Systems; country offices have to deal with information coming from different systems, making the collection and consolidation of information impossible. Systems are tailored to specific project and donor needs.

DME perceived as an outside expertise; project data is a by-product delivered to a donor or an expert who will do the analysis for us, this has created a high dependency on consultants.

High costs of development to the CO; each project develops its own MIS system, which results in a duplication of efforts and costs to the organization.

Training and maintenance costs for each system; costs to train and maintain the system are seldom considered in the design phase resulting in unexpected expenses not budgeted by the project.

Little or no experience in application development; lack of experience leads to poor systems or failures at a high cost to the organization. Systems developed with low quality require a high dependency on consultants to keep fixing the system.

Projects with little or no IT support for MIS; MIS perceived as a luxury that requires high IT investments. Certain countries have a low IT capacity that have not been structured to support complex project MIS requirements.

We have the data but not the information; We produce the data but we give little time to generate information out of it. Data is seen as a by-product of the project, collecting large amounts of data for data's sake.

1.5 Systematize Before you Automate

Systematization means the reduction to a purposefully regular method of organizing data and information. It is not about technology alone, the planning and organization of the information cycle in DME is independent of the development of technology solutions, and it can even be applied to a paper based system.

An Information System does not always means information technology. A Small project that has low information requirements and a small budget can have a successful project information system using low technology so-

lutions. Systematization of the information processes must preclude any effort to automatize. After all, technology can only help in making a process faster, but one has to define and design the process first. We define systematization as the organization of the project information management process.



Systematization: Reducing to a purposefully regular method of organizing data and information.

1.6 Audience

These guidelines are targeted specially to all project staff, supervisors and managers, including IT staff, who will be involved in the planning, development, implementation and management of the system. Other audience of the guidelines include Program managers and senior executives of the country office who will be end users of the information generated by the project. Anyone involved with DME and Information Systems is encouraged to read these guidelines.

1.7 Structure of the Guidelines

These guidelines are structured in seven chapters. Chapter 1 and 2 contain an introduction to the guidelines, and definitions of DME-IS. Chapter three presents the elements required in DME-IS from the logframe to the information cycle. Chapter 4 gives us an understanding of the basic components of DME-IS . The dimensions of Information Management is discussed in detail in chapter 5 which acts as an introduction to Chapter 6 that deals with the information management process. Chapter 7 introduces the development of an Information Plan to design the information process, implementation strategies, managing change, and evaluating and improving the DME-IS .

Future DME-IS guidelines will concentrate on the normalization and automatization of DME. Normalization refers to the definition of common data and information that a country office, RMUs and HQ will collect to measure and track organizational effectiveness (are we doing the right projects?) and measure and track operational efficiency (are we doing the projects right?). Automatization refers to the use of information technology to support the processes, it deals with the database systems required to man-

age project information, it will include a basic computerized desktop information system for managing project DME-IS.

1.8 Keep it Simple!

The purpose of these guidelines is not to complicate the project information process but rather to make it simple and achievable. These guidelines concentrate on the minimum basic requirements that any project should follow for a good information process. A good project MIS can be achieved by concentrating on the key elements required for proper monitoring and evaluation, without adding complex systems and processes, which only take away the time for analysis and decision making. Our recommendations in these guidelines are precisely that, to keep it simple.



Chapter 2 Defining DME-IS

2

2. DEFINING DME-IS

"Knowledge is experience....everything else is just information" Albert Einstein

What we mean by DME-IS is not necessarily information technology, but rather the common practices that need to be followed by any project for a good information management process. In this chapter we will introduce some basic concepts definitions and characteristics of DME-IS .

2.1 Definition of Project DME-IS

DME-IS is a set of interrelated components working together to collect, classify, store and distribute information to support decision making, coordination and control in an organization. It is about how we effectively manage our data, how we transform the data into information, useful for decision making, and how that information eventually becomes knowledge. This is the systematization by which a project manages its information resources.



DME-IS is a set of interrelated components working together to collect, classify, store and distribute information to support decision making, coordination and control in an organization.

What DME-IS not; it is not about technology alone, a good system, having a systematized process to manage information, can be effective whether it uses paper or computerized databases. DME-IS is neither information systems for specific fields, like accounting, health or economic development. DME-IS does not necessarily means a complex database or the need for expensive technology. DME-IS is neither about selecting the appropriate indicators o designing the project activities, all of which need to have been planned and established before starting a DME-IS .

2.2 Review of the Project Cycle in DME

In CARE's DME cycle, establishing goals and objectives and selecting indicators for measuring progress are the elements that form the basis of Coherent Information Systems. An important step in developing the system is the development of an M&E Plan. This plan outlines the information that needs to be collected, analyzed and shared during the life of the project.

DME-IS will focus on the systematization of information management processes. Once the project has completed the design and planning of the DME, the project should be able to move to a systemized process to gather, store, analyze and share all information maintained by the project

DME-IS fits in the DME cycle in the areas of monitoring and evaluation as the data collected gets analyzed to become information, which then becomes the input for good evaluations.

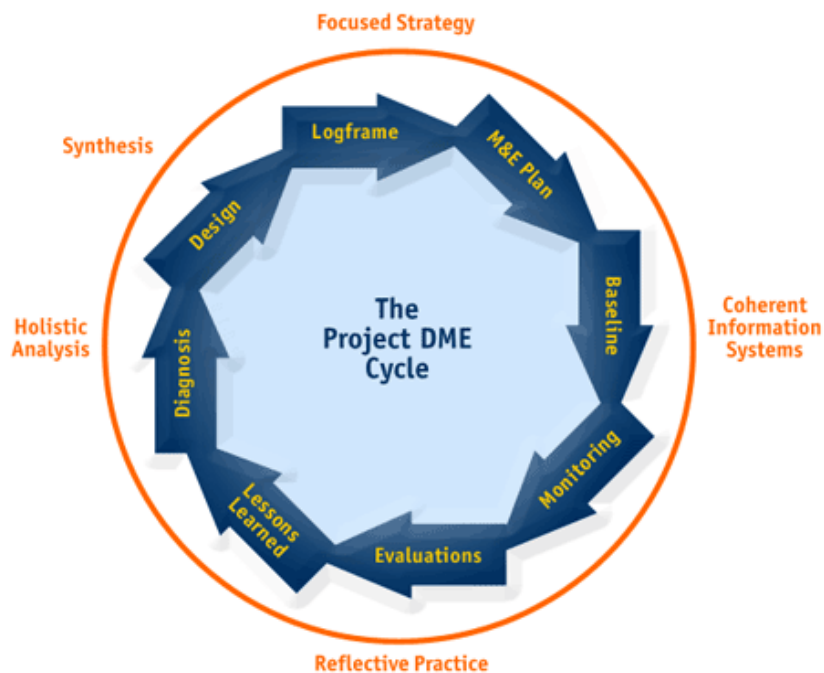

Figure 1 The DME Project Cycle ²

² CARE DME Project Standards

2.2.1 Definition of Monitoring.

Monitoring is the process of routinely collecting, storing, analyzing and reporting project information used to make decisions for project management. Monitoring provides project management and project stakeholders the information needed to evaluate the progress of the project, identify trends, patterns or deviations, keep project schedule and measure progress towards the expected goals. Monitoring information allows decisions regarding the use of project resources (human, material and financial) to enhance its effectiveness. When the right information is available at the right time and to the right people it can support decisions, like changes in the implementation strategies, that can help the project reduce costs and increase its outputs.³



Monitoring is the process of routinely collecting, storing, analyzing and reporting project information used to make decisions for project management.

Project monitoring is the continuous assessment of project implementation in relation to the agreed plans and the agreed provision of services to project beneficiaries. As such project monitoring provides invaluable information to managers and other project stakeholders on the progress of the project. Opportunely identifies potential successes or problems to facilitate timely adjustments to project operations.

2.2.2 Definition of Evaluation

Evaluation is the periodic assessment of a project's relevance, performance, efficiency, and impact (both expected and unexpected) in relation to stated objectives. As with monitoring, evaluation benefits from the process of information gathering to facilitate the assessment of the extend at which the project is achieving or has achieved its expected goals. Its findings allow project managers, beneficiaries, partners, donors and all project stakeholders to learn from the experience and improve future interventions. Qualitative and quantitative information are critical components of an evaluation, with out it, it is almost impossible to identify how project interventions are contributing (or not) to the project goals.⁴

³ CARE's Project Design Handbook, Richard Caldwell, p. 99

⁴ *ibid*



Evaluation is the periodic assessment of a project's relevance, performance, efficiency, and impact (both expected and unexpected) in relation to stated objectives.

2.3 The CARE International Project DME Standards

Standard nine of the CI project standards specify that every project should;

"develop and implement a monitoring and evaluation plan and system based on the logical framework that ensures the collection of baseline, monitoring, and final evaluation data, and anticipates how the information will be used for decision making; with a budget that includes adequate amounts for implementing the monitoring and evaluation plan."

This standard stresses the need to develop M&E plans that provide sufficient detail to identify the sources of information required for the design, monitoring and evaluation, means and schedules of measurement, data processing, analysis and dissemination and use of information by key project stakeholders.

2.4 Characteristics of DME-IS

In order to have flexible and responsive interventions, a project information system needs to be more than just a reporting mechanism, and serve as a management tool for advancing Country Office program goals of accountability, transparency and partnerships. A good project DME-IS needs to contain the following characteristics:

- a. The project information system should incorporate both quantitative and qualitative data and feedback from participatory assessments and evaluations continuously through every phase of the project. Systematic monitoring and evaluation of program processes and outcomes are particularly important where new programs are being implemented.
- b. Monitoring information systems supply the necessary information and feedback so that potential problems are identified and solutions are implemented early before becoming constraints. The system should be able to generate enough information to initiate a corrective action.

- c. A Project DME-IS is a tool to collect, analyze, store and disseminate information useful for decision making in a project. A good DME-IS builds on a project's successes while using lessons from earlier experiences to improve project performance.
- d. Project management information systems differ from other country Management Information Systems because their demand-driven approach requires the DME-IS to be very flexible.
- e. Flow of information is central to DME-IS and constitutes an empowerment agenda that includes:
 - i. Transparency - the availability and access to information by all project stakeholders
 - ii. Accountability - the use and application of information to monitor the progress of the project and correct deviations.
 - iii. Inclusion and participation - where project participants are given control over decision-making, including decisions on appropriate criteria and indicators to judge the performance of the services provided by the project.

2.5 DME-IS levels of Technology

DME-IS does not necessarily mean a state-of-the-art technology solution that tries to be everything to everybody. Every project has different information needs both in quality and in quantity. Every project requires different levels of technologies to satisfy its basic information management needs, a small project with small needs will suffice with simple technologies, but large projects with large information needs can benefit from more extensive technological solutions.

These levels help define the technology required based on the information requirements of a project:

1. Level one is a paper based information system for small projects where use of technology is not required or not available.
2. Level two requires the use of basic computer applications to manage project information.
3. Level three identifies the use of databases to manage the increased volume of information.
4. Level 4 will require a fully integrated DME-IS system.

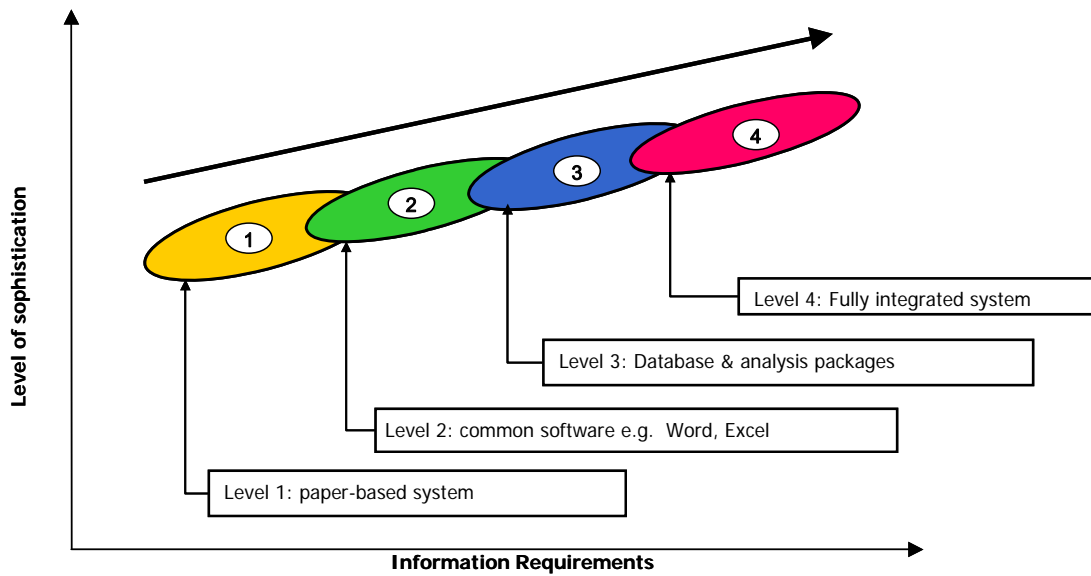

Figure 2 The DME-IS levels⁵

The circles 1-4 (with numbers) refers to the four levels progressively from easier (level 1) to the more difficult (level 4). The overlapping ovals denote the occurrence of simultaneous characteristics among two levels.

The upward-slanting arrow (from left to right) - represents the rising technical and resource requirements for setting up an increasingly automated information system and the ever greater complexity of the system itself as a project shifts from level 1 toward level 4.

This classification of levels is for guiding projects in assessing their location on the continuum of lower to more sophisticated information systems. During the life of a project the levels may change, while on the other hand, a CO with several Projects, programs, and sectors may have each one at a different location on the continuum.⁶

Becoming more sophisticated (or automated) may not be appropriate or feasible in some situations, due to local conditions or external factors. It can be acceptable for a CO to remain at level

⁵ DME-IS conference report 2001

⁶ Ibid

one, as long as it has a system that provides with good quality and reliable information. A major imperative lies in the need for a coherent systematization of information handling as part of the information management process, and this must occur before automating (adapting the technology to the process).⁷

The use of complex technology not necessarily means efficiency. A small project with little information needs will not benefit from a complex integrated system. On the contrary, managing the system can even be less efficient than a simple manual solution. A project needs to determine its information requirements and match it with the appropriate technology.

The graph below shows the relationship between the volume of information and the quality of an information system comparing the four different levels shown above:

Each level drops in its efficiency as the volume of information grows. Projects need to identify when to move to the next level

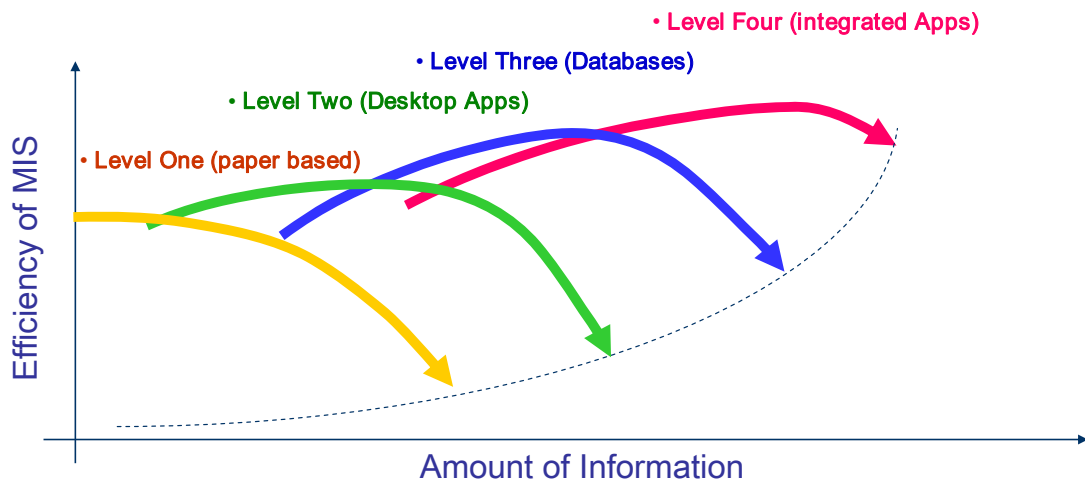

Figure 3 Efficiency of DME-IS

As the amount of information increases for a given level, the efficiency in the use of an MIS tends to decrease due to the time it takes to process, analyze and report the additional information. For example a level two system decreases in efficiency as the volume of information increases. This does not necessarily mean that a level 4 is the ideal, quite the opposite, a level 4 shows a low efficiency when the volume of information is small.

⁷ Ibid

This can be seen when using a complex system to track small amounts of information, the effort to setup, manage and use the system, and all its associated costs, make a level 4 system less efficient compared with simpler solutions.

Levels of information systems complexity and suggested management and software support.⁸

	DME-IS Levels			
	1	2	3	4
Complexity	No software necessary (may use), electronic calculator or 'paper & pencil'	Word processor, Excel	Software examples: Arc view GIS, SPSS, Strata, MapInfo GK, EPI-Info (software for nutritional data analysis), LAN	Software (as before) plus server software and computer that can support DDBMS at the CO, RMU, and CI (global) level
Requirements	Simple file organization,	Safety, backup, storage, retrieval, access, security, flexibility	Software specifically designed for project needs, ability to export/import to/from other systems	Open architecture software (for interface with HQ and CI + other permitted users); all standard safety features.
Some expected outputs	Sum, average, (calculations by hand)	Texts, simple charts/figures	More complex analysis, charts, maps and analysis, correlation etc.	All sorts of required analysis and presentations. Internet

⁸ DME-IS Conference Report, 2001

2.5.1 Level One, Paper based Systems.

This situation is typical of a small project with small information needs, or where the use of technology is limited. Most information is captured and stored on paper forms and manual analysis is done to report progress and results to management. Within this level there is less dependency on information technology and the project information is managed by simply organizing the forms, and data collected in binders and folders for easy reference or consultation.

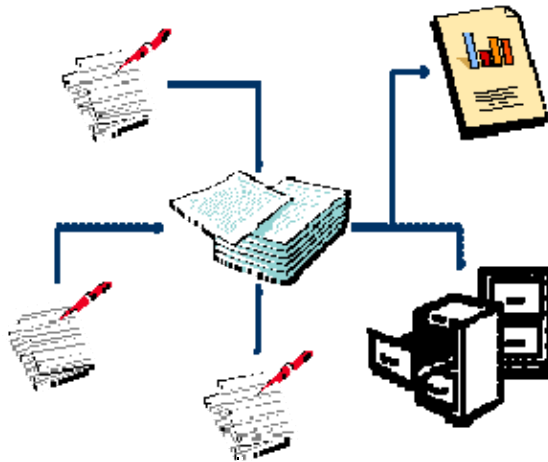

Figure 4. Level One

Level one assumes that the volume of information the project manages is small enough to be managed on paper. A desktop computer may be used to consolidate data from forms into reports that are printed and sent to supervisors and donors. All the information is available on hard copies and searchable by an indexing system on the project's document library.

2.5.2 Level Two, Desktop Applications

Level two relies on the use of computer desktop applications (like MS Office suite) to organize and store data and produce reports. At this level the volume of data requires a simple information technology setup. One or two computers to organize the information collected and produce the desired reports.

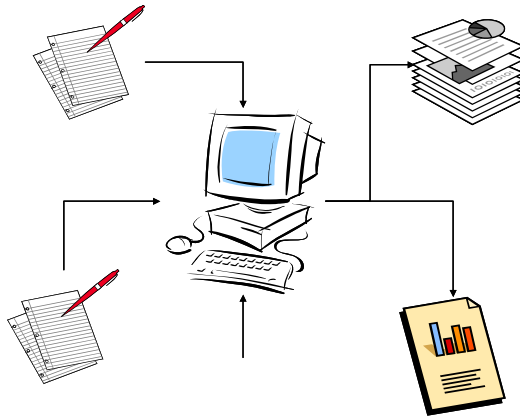

Figure 5. Level Two

Level Two assumes the volume of information to be somewhat considerable, all of the data comes in physical form but are entered on a computer to produce monthly reports. All information is stored on the computer and on physical files, while reports and other consolidated information is stored on a computer hard disk

2.5.3 Level Three, Database Applications

Level three uses more computers to manage decentralized databases that contain most if not all of project information. These databases may not be totally integrated but fill the need to organize large amounts of data collected by the project and generate the required reports.

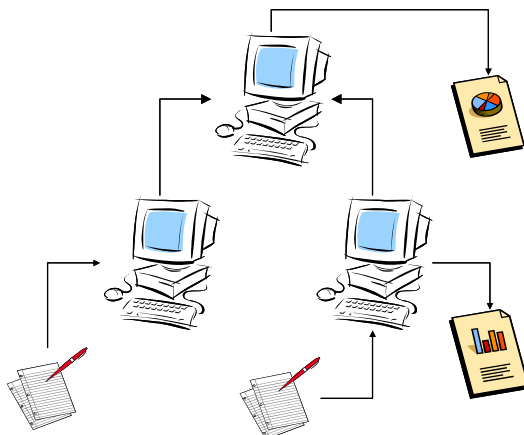

Figure 6, Level Three

The level of data at this level is large and may come from different sources and project locations. A central database may be used to consolidate data for reporting purposes. All data and reports are stored on computers. There is less need to store physical records. The database collects information and generates all required reports.

2.5.4 Level Four, Integrated Systems

Level four requires an integrated view of project data and information processes. It requires a network where all computers are connected and sharing data from a central system that stores project data and information. Solutions are integrated and may contain other type of project data, like budget, human resources and external or secondary data. This situation is typical of large projects disseminated in many locations and in a country that

has the required connectivity to link all systems with the central database.

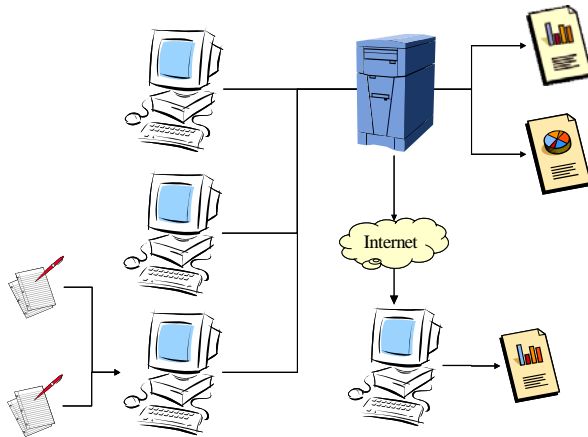

Figure 7, Level Four

The volume of data in level four is quite large and requires dedicated resources to manage the system's technology. All data is stored on computers and accessed via the network or the internet. Access to information is controlled by a central system and security features implemented to protect the data.

2.6 Identifying a project's MIS technology needs

2.6.1 Information Requirements

Based on the above examples a project needs to identify the required level of technology, the table below is a tool to help managers identify the characteristics of the information needs and technology capacity to define the appropriate level. The first step is to evaluate the level, volume and complexity of the information the project will manage, this will determine the level of Information Requirements.

Project Information needs	Level 1	Level 2	Level 3	Level 4
What are the requirements of information from the donor in terms of volume?	None	Low	Medium	High
What are the requirements of information from the country office management in terms of volume?	None	Low	Medium	High
Are there any local government policies or requirements to provide information?	None	Low	Medium	High
How often do we need to collect, and organize our information?	One or two times a year	Four to six times a year	Every month	Every week or more

How often do we need to analyze, report our information?	One or two times a year	Four to six times a year	Every month	Every week or more
What is the volume of information we need to collect from Beneficiaries?	None	Low	Medium	Large
What is the expected volume of surveys the project will undertake?	None	Low	Medium	Large
Do we need to do complex analysis on the data collected?	No	A few	Some	Several
Do we need the use of complex software packages? (SPSS, EPI Info, MER)	No	A few	Some	Several
Selected Level			X	

Count the number of times each of the levels was mentioned, the level with the most responses is the required level of information complexity for the project. The next step is to evaluate the current IT capacity of the project. This will let us know if we have the IT capacity that will satisfy the information requirement level from above

Project Technology Capacity	Level 1	Level 2	Level 3	Level 4
Do we have IT resources dedicated to the project?	No	No	yes	yes
What is the project's capacity to manage technology?	None	Low	Medium	High
Does the project site have good communications, email, internet, etc.?	None	Regular	Good	Excellent
How many staff will be using computers on the project?	None	Very Few	Most	All
What is the level of computer literacy of the project staff?	None	Low	Medium	High
Will the main office provide us with IT support?	No	Very Few	Some	Yes
Can we obtain good IT support near the project locations?	No	Very Few	Some	Yes

Current Level		Yes		
Required Level			Yes	

The project has identified that its current capacity is on level 2 but the desired level, to meet its information needs, is level 3. The project then needs to build its IT capacity in the areas that have workable solutions

Selected DME-IS level	Level 1	Level 2	Level 3	Level 4
Information Requirements			X	
Technology Capacity		X		
The project has selected the following level (or mix of levels)		X	X	

The table above is an example of a project that has large information requirements but low technical capacity. A project always needs to make a gap analysis to identify the current state and define what is needed to reach to desired state. In the above example the project has two alternatives; to increase its technology capacity or negotiate and reduce its information requirements.

2.6.1 Technology Requirements

Once a project has identified its information requirements it needs to define its technological requirements. Based on the number of users and need to manage information, the project , with assistance from the IT unit, can begin the design a technological infrastructure that will provide with the appropriate hardware and software needed to manage the information.

2.7 From Data to Information to Knowledge and Wisdom

“Where is the Life we have lost in living? Where is the wisdom we have lost in knowledge? Where is the knowledge we have lost in information?...” T.S. Eliot

We can add to the above phrase. Where is the information that we lost in data. To fully understand DME-IS, an important step is to realize the hierarchy of data to wisdom as a key component of what we are trying to achieve with information management. Without the proper data we cannot have good information, without good information we cannot create knowledge, and without knowledge we cannot experience wisdom. To better understand this relationship we need to first to have a good definition of data, information, and knowledge and how they relate to information management:

Data is defined as a base representation of a fact, represented in the form of numbers, letters, or words. Examples of data include number of visits to a community, number of crop failures, number of farmers trained. Data is a discrete set of unorganized, scattered statement about a reality. Data are raw facts.



DATA: un-processed collection or representation of raw facts, concepts, opinions or instructions in any medium or form, including textual, numerical, graphic, cartographic, narrative, or audiovisual forms in a manner suitable for communication, interpretation, or processing by humans or by automatic means.

Information is defined a data with context, or “data endowed with relevance and purpose”⁹ Data becomes information when is placed within a context. An example of information is; 80% of the farmers who kept the same variety of coffee, lured by market prices, could not sustain three continuous crop failures and defaulted their loans. Information is organized data, with a meaning and relevant. Information is facts with context and perspective.

⁹ Peter Druker



INFORMATION: The interpretation of data based on its context. An assembly of data in a comprehensive form capable of communication and use. Information is the result of processing, manipulating and organizing data which meaning is assigned, according to context and assumed conventions.

Knowledge is information in action or the ability to understand the relevance of information and to understand how to use that information to advantage. The use of information leads to experience, and new knowledge. Knowledge is information that is embedded in a context, has a purpose and leads one to take an action. Knowledge allows us to make sense of information, relate information to our lives and know when information is irrelevant. Example, A farmer has learned that by rotating crops he is less exposed to crop failures, he tried different varieties and with his previous knowledge about the soil and weather conditions in the region, and technical information he received from CARE extensionists, has come up with the right mix of crops that produced a good harvest and allowed him to pay his loans and provide for his family. Knowledge is information with guidance for action.



KNOWLEDGE: Information evaluated and organized in the human mind so that it can be used purposefully, knowledge is information with guidance for action based upon insight and experience.

Knowledge requires a human interaction with information. Information becomes knowledge when a person acts on it, makes it her/his own, conceptualizes it by placing it in relation to previous knowledge and internalizes it by making it part of her/his beliefs.

Wisdom is knowledge with insight or the capacity to know what body of knowledge is relevant to the solution of significant problems. Information can tell us that something happened, knowledge can tell us how it works, but wisdom allows us to identify the bodies of knowledge required to evaluate whether it is a positive or negative development. Wisdom means knowing what questions to ask. "The farmer now has wisdom on how and were to get more information and has knowledge on how to apply this information to solve his problems. Wisdom is understanding which knowledge to use for what purpose.



WISDOM: The ability to use knowledge for a purpose, ability to apply knowledge or experience, understanding or common sense and insight. Knowledge, gained through personal experience, that allows to understand how to apply concepts from one domain to new situations or problems



Chapter 3 Fundamentals of DME-IS

3

3. FUNDAMENTALS OF DME-IS

"Knowledge becomes wisdom only after it has been put to practical use." Mark Twain

3.1 The Core Processes of DME-IS

The word *system* implies a collection of many different components working together for a particular purpose. But all too often, the expression *information system* gets mixed up with concepts of information technology, and is understood to refer to a computer system. Computers certainly have a role in most project information systems, but they are merely one component of the system, a tool for speeding the handling of information. Instead, system here refers more to a set of operational procedures for the collection of data from a range of different sources, the processing of that data to produce useful information, and the application of that information to improve the project outcomes.

A more precise definition puts a system as "...a group of interacting, interrelated, or interdependent elements forming a complex whole"¹⁰ this system is formed by the different processes around information dimensions required to monitor a project. The information management process relate to the steps that a projects needs to gather, store, analyze and report information, as well as identify type, sources and uses of information. A system is not necessarily a computer based system but a set of related processes that form a whole.

By process we mean the set of activities that a project does in order to obtain information to make decisions. This process is independent of the type of project or program, and provides man-

¹⁰Excerpted from *The American Heritage Dictionary of the English Language, Third Edition* Copyright © 1992 by Houghton Mifflin Company. Electronic version licensed from Lernout & Hauspie Speech Products N.V., further reproduction and distribution restricted in accordance with the Copyright Law of the United States. All rights reserved.

agement with the key information to monitor the project. The DME-IS process is therefore the methodic and regular sequential set of activities to manage data and transform it into useful information, information that leads to action and the creation of new knowledge.

The DME-IS information management process consists of 8 basic steps

1. Define the information needs
2. Locate the information sources
3. Select the information needed
4. Collect the information
5. Organize and Store information
6. Analyze and Report the information
7. Share and Use on the information
8. Evaluating and Improve the process

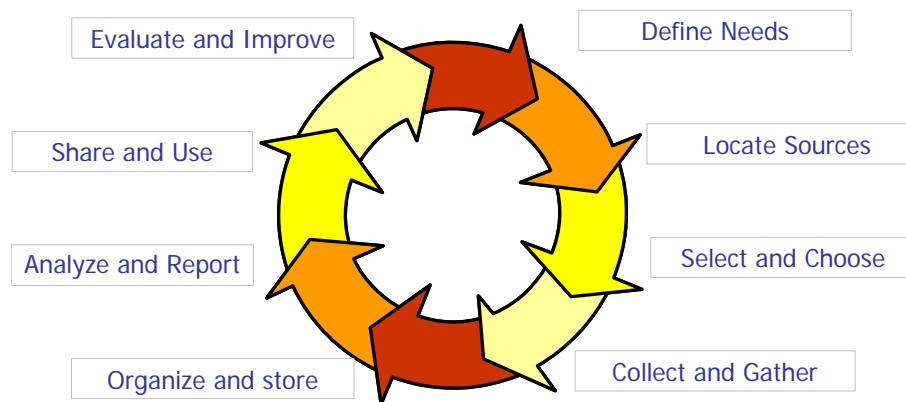

Figure 8 Information Management Process

The above steps are further explored on chapter 6; each step is part of the overall information management process, a process that takes in consideration the following:

- The stakeholders who will use the information to make decisions.
- The data that needs to be collected and converted into useful information within the context of the project
- The process that defines how the stakeholders relate to the information

- The tools required to manage the process and facilitate the gathering, storing, and analysis, reporting and sharing of the information.

3.2 Managing the Information Process

Managing information requires the same level of discipline as the management of other organizational process (procurement, hiring, etc.), by adequately taking care of each one of the process required to manage information the project can have control on the outcomes of the process and be confident on the quality of the information generated.

We need to treat information as a strategic resource and manage it accordingly, the same way we manage people, financial and physical resources. A project needs to have the adequate resources and skills to bring the right information, to the right people at the right time. It is through information management that a project can improve its decision making process, learn and create new knowledge.

Information management is the process of creating, identifying, collecting, organizing, sharing, adapting and using the information on practices that have produced outstanding results in other situations and that could be adapted to another situation. If we defined knowledge as information in action then when information is used and applied to the context of the project is when new knowledge is created. Knowledge resides in people's experiences; this "intellectual capital" is one of CARE's mission critical assets. Information on practices in the field and information on current methodologies, solutions and approaches need to reach an ever wider audience that in many cases lies outside CARE's organizational boundaries.

The DME-IS information process can be described as a logical chain of linked ideas that start and continue with information users.

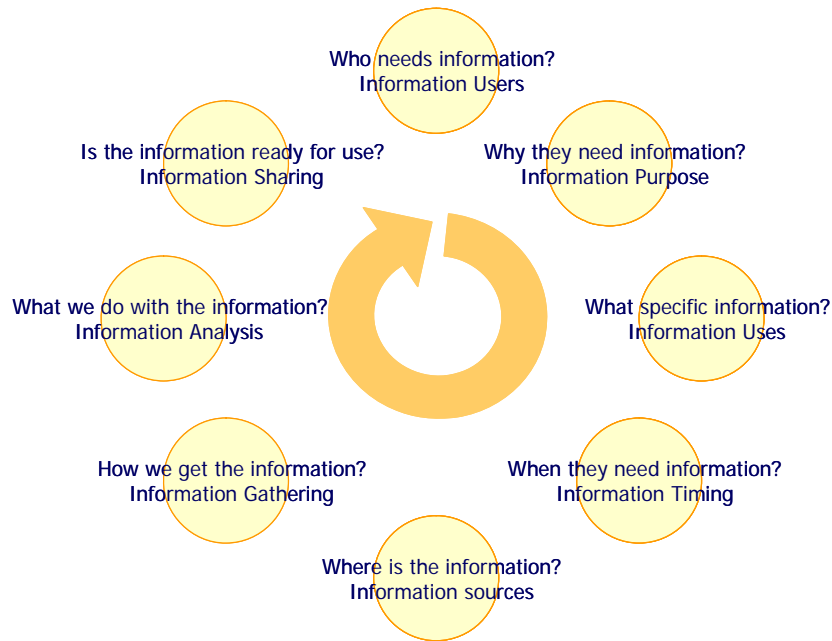

- Information Users include persons who are influenced by projects as well as those who influence the project, e.g., target communities, project staff, donors, country office management, etc.
- Information Purpose is the specific information needed in order to ensure that the project is relevant, efficient and effective within its stated objectives.
- Information Uses include informing decisions in the project and sharing information with other persons or organizations.
- Information Timing is delivering the information when is needed. If certain information is needed, but it is not feasible to collect it or it can't be collected in time, then the project may get off track, i.e., it can become ineffective or irrelevant to local priorities.
- Information Sources, is locating where and who has the information and what will the project need to do in order to have access to it.
- Information Gathering is collecting in a systematic process the information needed.
- Information Analysis means that the information collected can be used by the project stakeholders to identify trends, problem areas or opportunities.
- Information Sharing, if the information is collected and analyzed but not available to the persons who need it,

critical decisions about the project may not be made or may be poorly taken

3.3 Depth of detail in DME-IS (keep it simple)

Although there is no physical limit to the volume of information any system can collect, there is a limit on what the project staff can manage. A small project will require low volume of information organized in such a way that can be managed. A project MIS could technically collect every detail of information available but managing this volume could be both expensive and result in inefficiencies. A project needs to determine what is the level of detail they need to collect that is both manageable and supportive of its objectives.

Our recommendation is always to keep it simple and define only the information that will eventually be used. A simple rule to apply is to always question if the data collected has been used to make decisions that improved the results of the project. If the information collected was never used then the project needs to consider the value of the information and decide to stop collecting it. Information needs to add value to the project.

3.4 Log Frame and DME-IS

The Logical Framework (logframe) is the term used to the logical structure of a project's information. A logframe is a project management tool constructed during the project design phase and is a structured summary of the project design information needs. It should be flexible; that is, there should be opportunities for refining the details during the life of a project as more is learned about the realities of conditions in the project area.

DME-IS is based on the Logframe as the framework from which all information will be organized. It is from the Logframe that we can connect project objectives with project activities and measure impact and progress, but most important it keeps the relationship between outputs and effect in a way that managers can evaluate the contribution of the outputs to the objectives of the project.

When the Logframe is applied to DME-IS one obtains the following benefits:

- A consistent link between the inputs/activities/outputs and the outcomes/impact of the project.
- A systematic approach to organize the activities of the project under specific outcomes and objectives.
- A means to see which outputs were significant in achieving outcomes.

The typical logical framework consists of a 4 x 4 matrix, with a vertical hierarchy of objectives at the (1) project final goal (impact), (2) intermediate objectives (effect), (3) output, and 4) activity levels. The horizontal components are (a) summaries of the objectives at each level, (b) performance indicators for achievement of those objectives, (c) the sources and means needed to verify the indicators, and (d) the important risks and assumptions for moving from one level of objectives to the next.

Typical Log Frame Structure

(a) Project Structure	(b) Indicators of Achievement	(c) Means of Verification	(d) Important Risks and Assumptions
<p>(1) Project Final Goal (Impact Goal)</p> <p>What are the wider objectives which the project will help achieve? Longer term program impact</p>	<p>What are the quantitative measures or qualitative judgments to know whether these broad objectives have been achieved?</p>	<p>What sources of information exist or can be provided to allow the goal to be measured?</p>	<p>What external factors are necessary to sustain the objectives in the long run?</p>
<p>(2) Intermediate Objectives (Effect Objectives)</p> <p>What are the intended immediate effects of the project, what are the benefits, to whom? What effect, improvements or changes will the project bring about?</p>	<p>What are the quantitative measures or qualitative judgments, by which achievement of the purpose can be judged?</p>	<p>What sources of information exist or can be provided to allow the goal to be measured?</p>	<p>What external factors are necessary to contribute to achievement of the goal?</p>
<p>(3) Outputs</p> <p>What outputs (deliv-</p>	<p>What kind and quality of outputs and by</p>	<p>What are the sources of information to</p>	<p>What are the factors not in control of the</p>

(a) Project Structure	(b) Indicators of Achievement	(c) Means of Verification	(d) Important Risks and Assumptions
erables) are to be produced in order to achieve the intermediate objectives?	when will they be produced? (Quantity, Quality, Time)	verify the achievement of the outputs?	project which are liable to restrict the outputs achieving the Intermediate Objectives?
(4) Activities What activities must be achieved to accomplish the outputs?	What kind and quality of activities and by when will they be produced?	What are the sources of information to verify the achievement of the activities?	What factors will restrict the activities from creating the outputs?

Logframes are living documents, which may change over the life of the project according to changes in the dynamic external environment and to any alterations that need to be made to the outputs. The information contained is generated during the design of the project and is used to manage project implementation. The logical framework must show how progress towards the project purpose will be achieved.

CARE Logframe Terminology¹¹

	Impact	Outcomes	Outputs	Interventions
CARE terminology	Project Impact	Effects	Outputs	Activities
CARE Logframe	Project Goal	Intermediate Objectives	Outputs	Activities



The Project Logframe is based on the initial assumptions the project identified from the diagnosis and design phases. As the project makes progress those assumptions need to be checked again for validity as external or internal conditions may have changed, making some element of the Logframe irrelevant

3.4.1 Project Final Goal (Project Impact)

The ultimate aim or purpose of the project, described in clear terms to reflect a measurable and defined improvement in human conditions, expected to take place in a target group, in an

¹¹ CARE Impact Guidelines, October 1999.

expected period of time. What the project intends to contribute in the long term as a result of achieving the intermediate goals, e.g., improve the rural standard of living.

3.4.2 Intermediate Objectives (Project Effects)

The intended changes in systemic conditions or behaviors that must be achieved in order to accomplish the impact goal; that is, each effect objective is a necessary condition to achieving the impact goal. What response the project intends to achieve among the target population groups, e.g., increases the production and sale of high quality rice by small farmers.

3.4.3 Outputs

What the project intends to achieve in the short term as a result of the project activities. E.g., 100 farmers trained to carry out improved rice farming

3.4.4 Activities

What the project staff and target population are going to do. E.g., provide technical support to existing farmer groups. This is the 'lowest' level in the sense that it occurs first, and is completely dependent on project inputs.

3.4.5 Inputs

What resources are necessary for performing the project activities? E.g., stationery supplies for workshops and training sessions. These are not usually shown in the log frame itself, though they are a key element in producing project outputs. Inputs occur only during the period of project support.

3.4.6. The Graphical Logical Framework or Work Breakdown Schedule

A Logframe can be visualized in different ways, under the DME-IS the logframe takes a new format to present the connections between objectives and activities. The need to visualize the projects outcomes becomes an imperative in order to better understand the relationships between inputs activities outputs and the higher objectives and goals of the project.

The Work Breakdown Structure (WBS) is another planning tool used to define a project in terms of its outputs while providing a

method for breaking these deliverables into meaningful work units. The WBS allows the project manager to clearly describe the hierarchical nature of the work to be performed and establishes a foundation for other elements of the project planning documents including the project's resource plan, budget, implementation plan, and project schedule.

With the WBS, project managers will be able describe the outcomes of a project in a way that is clear to members of the project team as well as the project's stakeholders, beneficiaries and donors, while at the same time capturing the order and sequence of the work necessary to produce those outputs. The WBS provides a means for carefully detailing the outputs of the project and facilitates the identification of specific the work elements, and groupings required to deliver each element. Additionally, once it is complete, the WBS becomes an essential building block and reference point for other project plan components.¹²

The chart below is an example of the WBS format.

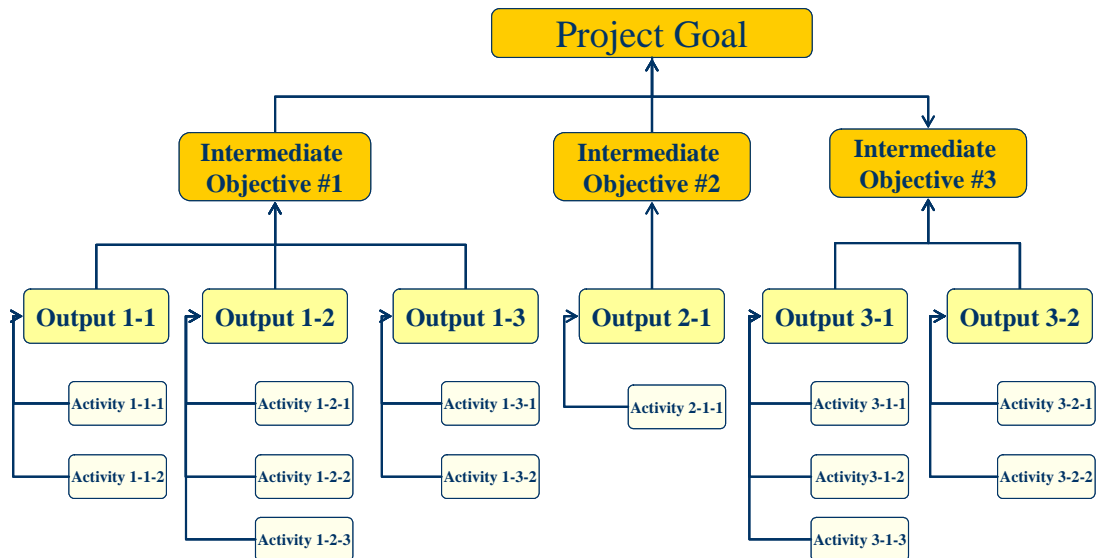

Figure 9 Graphical Logframe WBS

¹² Project Management Institute, WBS Standards, 2003

In the above example it's much easier to see how the project activities are organized under each corresponding output and each with is corresponding project objectives.

One significant value of the logframe, within the context of an information system, is the ability to show were the project achieved its initial goals and were is lagging behind, this helps managers reallocate resources and efforts to those areas that need more inputs.

As an example the chart below demonstrates how a logframe can be organized to show the links between project objectives and the indicators that measure progress.

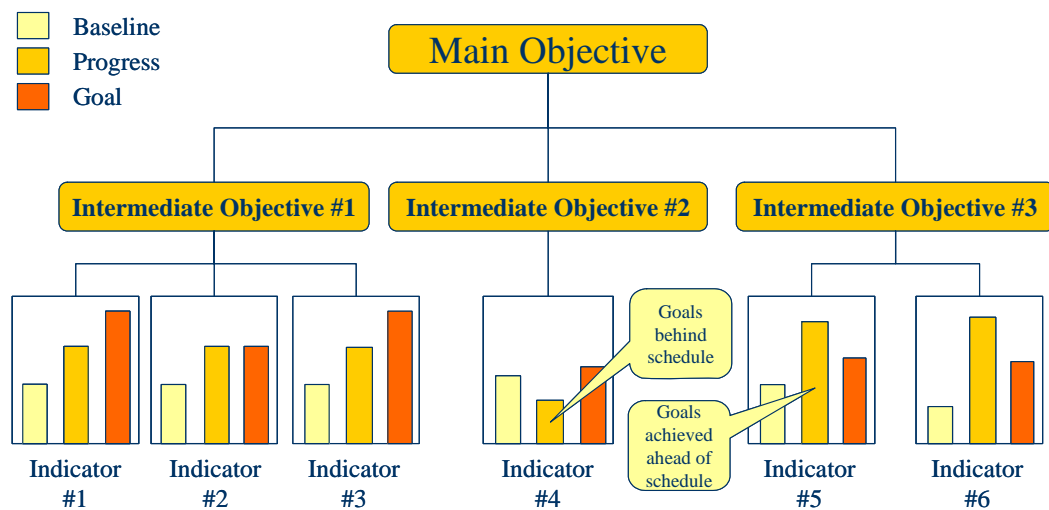

Figure 10 Logframe and Project Indicator's Progress

The chart above shows the progress on each intermediate objective indicator. Shows the baseline value, the progress to date value and the expected goal value of the indicator.

From this view one can see that indicators 2, 5 and 6 have been met before the end of the project, while indicator 1, 3 and 4 are still below target.

This could be a typical case of a project during its midterm evaluation. From this information a manager can deduce that no more effort is required to achieve the intermediate objective #1 and resources can be reallocated to improve indicators 4 and 5.

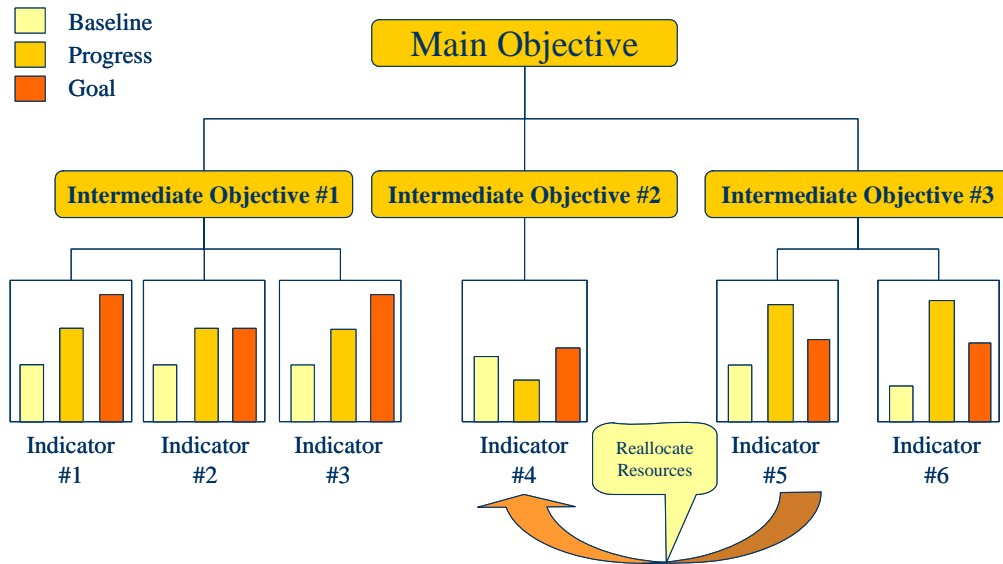

Figure 11 Logframe and Project Resource Reallocation

Once the project has reallocated resources to improve the outputs of the intermediate objective, the project can then monitor and evaluate the impact of these actions. The picture below shows how the indicators have been able to improve due to the reallocation of resources.

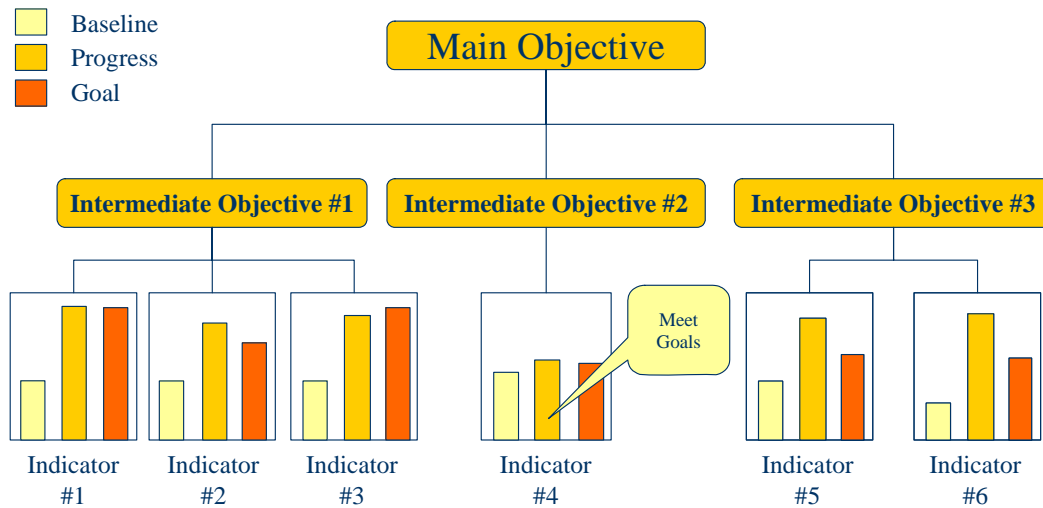

Figure 12 Project Indicators Improvement

3.5 DME-IS at the Project Level

The main Focus of DME-IS, at the project level is to track project inputs, activities and outputs. This is the day to day information and data management that DME-IS does at the project level. The process at this level has two targets, short term information that can be made available on a monthly basis, and long term information obtained via surveys, evaluations and case studies.

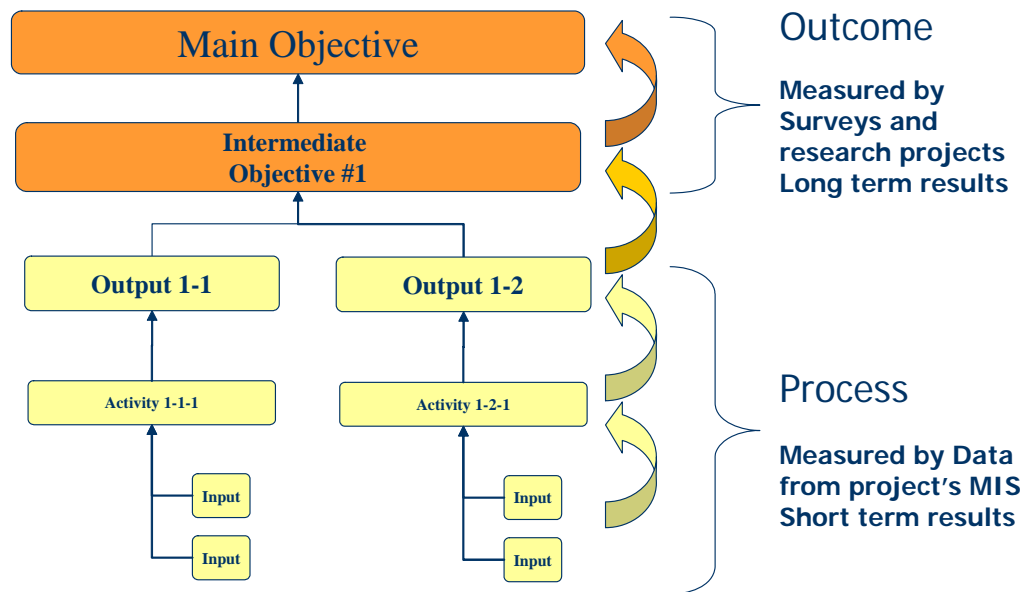

Figure 13 Relationship between Process and Outcomes

3.6 DME-IS at the Country or Program Level

At this level DME-IS looks to consolidate all project data and compares them to program or country office objectives, these can be country statistics; poverty indicators in the areas where the project office operates. By consolidating information country office management has a bird eye view of where the projects are in relation to their objectives, and the potential areas of problems, delays or cost overruns. At this level the country office needs to be able to consolidate all project information using agreed report formats to measure and track project progress against expected objectives.

3.6.1 Project Portfolio

At this level a country offices manages the project portfolio and is most interested in tracking project progress. The need to know in advance which project are on track and which projects are behind helps management focus on the potential problem areas that will require their attention. This portfolio view doesn't need to be complicated and a simple summary report from each project showing progress made against expected schedules can be made available in a standard format easy to read and interpret.

An example of a project portfolio dashboard presenting the status of 5 projects is shown below:

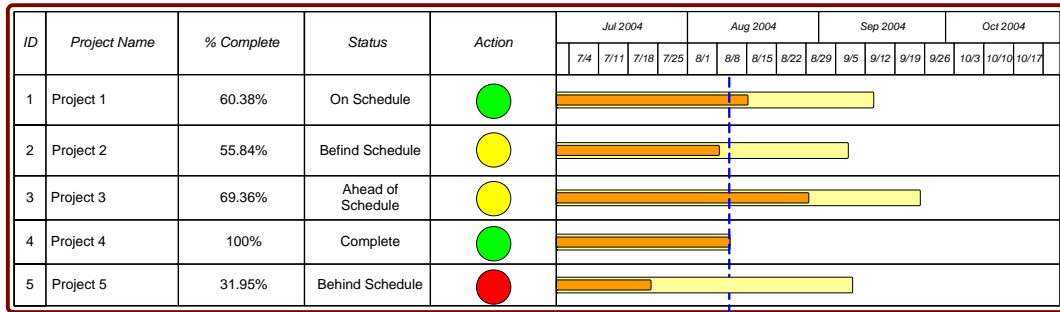

From this simple view one can easily see that project 2 and 5 are showing considerable delays, and management should provide more attention and support to it. Projects 1, 4 and 3 from the information shown seem to require little supervision. Supervisors then can ask for more detail on the projects that are behind schedule, including budget status.

The example below shows how additional information can be useful to decision making:

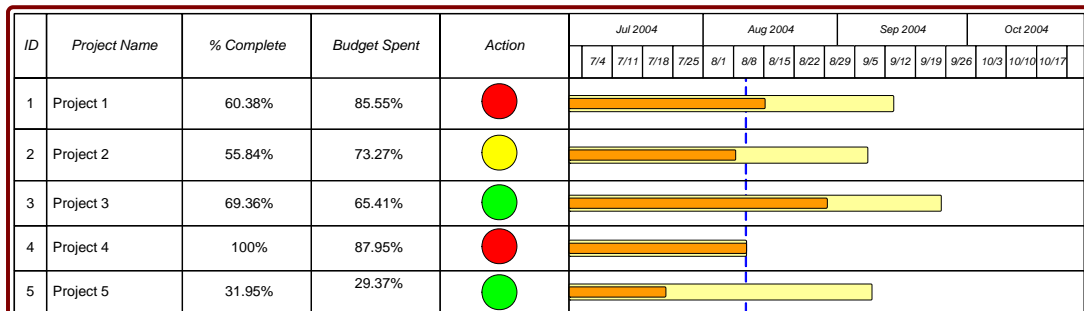

From the above report one can see that even though project 1 is on track, but its budget is not. Project 2 is behind schedule but is running out of budget, this is a potential risk with a donor. Project 4 has completed its schedule but still has 15% of its budget not spent. Data within a context creates information, that made available on time can help management in taking corrective actions before it's too late.

3.6.2 Program Portfolio

This view of project information as a program portfolio can also help in identifying how our projects area addressing the root causes of poverty, and how a country office may need to balance its portfolio to obtain a balanced mix of projects addressing the most important factors.

The example below shows how a country office can organize project information in a portfolio to evaluate if the country office is doing the right projects. The example shows project type by budget size on a chart measuring the number of direct beneficiaries and the level by which each project is addressing the root causes of poverty. The four quadrants of the chart help place each project within this framework. A country office ideally will need to increase the number of project on the upper right quadrant which bring the more benefits to more beneficiaries.

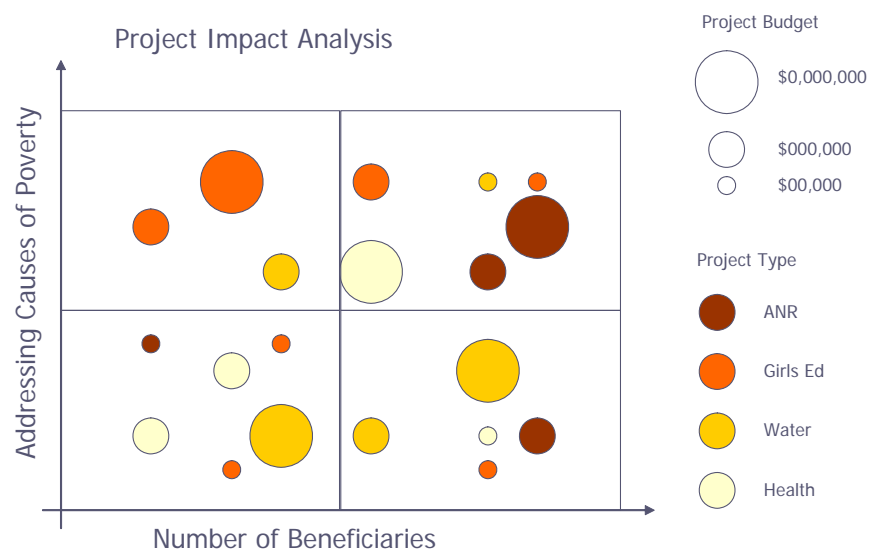

Figure 14 Example of Country Office Program Portfolio

3.6.3 DME-IS and GIS

DME-IS at the CO level should not be limited to internal information, A good project MIS could add information from the country to add context to the data provided by projects. This can be easily done using a geographical information system to visualize project information and map it against a country's poverty map. The example below shows how this information can be presented to management:

A map can be a powerful method to show information. It provides with a simple yet complete view of the context where projects intervene, and lets management know if the projects are located in the poorest areas or not.

This information is also useful in presenting proposals to donors.

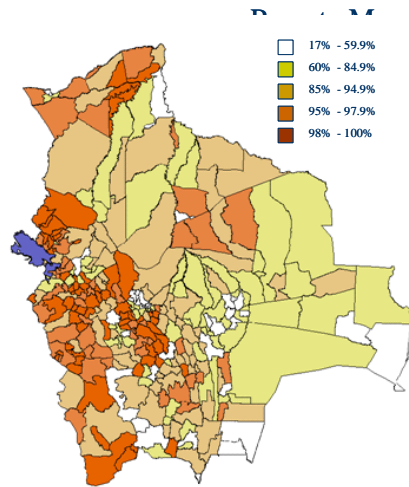

Figure 15 Country Poverty Map

3.6.3 DME-IS and MDG's

Country office management can organize the information of all its projects by the level in which each one is addressing or contributing on one or more of the Millennium Development Goals.

Millennium Development Goals.	Project 1	Project 2	Project 3	Project 4	Project 5
Goal#1 Eradicate extreme poverty and hunger	Low				
Goal#2 Achieve universal primary education.			High	Medium	
Goal#3 Promote gender equality and empower women.	High				
Goal #4 Reduce child mortality.	Medium	High	Medium		
Goal#5 Improve maternal		High		High	

health.					
Goal #6 Combat HIV/AIDS, malaria and other diseases.			Low		High
Goal #7 Ensure environmental sustainability.					
Goal #8 Develop a global partnership for development		Medium		Medium	High

Level of project's contribution to MDGs

The above example can be useful in determining how much the CO is doing to contribute to the MDGs.

3.6.3 Historical Information and Trend Analysis

A country office can benefit from a portfolio view of its projects and be able to organize the information to understand better the trends and changes that have been happening over time. A portfolio can show API type information at a country office level, classifying projects by type, sector and budget.

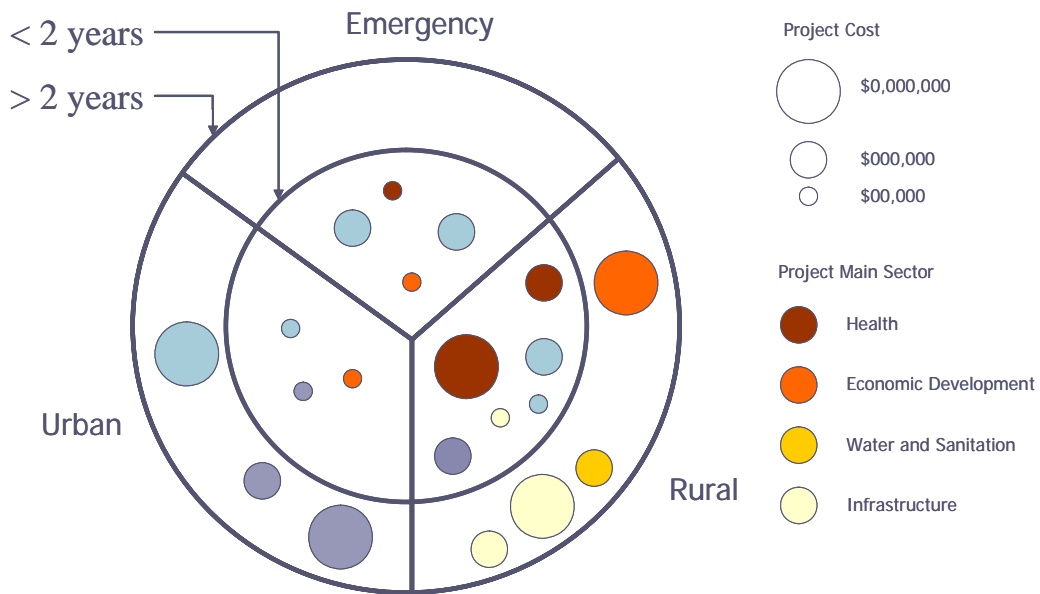

Figure 16 Classification of Projects at Country Office Level

Another example of project portfolio can be seen in the chart below. Here a CO is able to see programmatic trends from the last nine years.

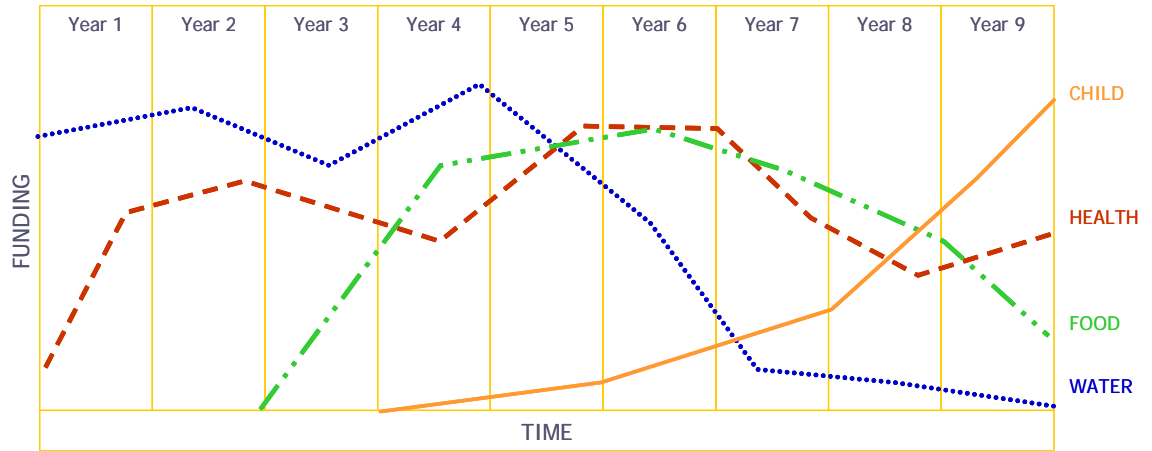

Figure 17 Funding Trends

The above representation of information provides insight on the future and helps a country office prepare for the changes that will occur. The graph above can include information on donor funding trends for the country or the region to see if what the country office is experiencing is a general trend or if the CO is missing opportunities.



Chapter 4 Components of DME-IS

4

4. COMPONENTS OF DME-IS

"Not everything that can be counted counts and not everything that counts can be counted" Albert Einstein.

Any information system must be built with enough flexibility to accommodate the specific needs for all projects but at the same time must comply with basic standards that make analysis of the project progress available at all levels of country office management. For this to happen the country office needs to standardize the basic information components of each project. Depending on the nature and information complexity of each project, the system will contain a basic core or central module that structures the project's basic set of information. Each project can then add more complex processes and modules as the specific needs of the project may require it.

The components are a way of categorizing basic information into logical groups, each with its own set of processes for information management. Each component defines the minimum information elements that a DME-IS should have. There are 7 basic components for a good MDE-IS:

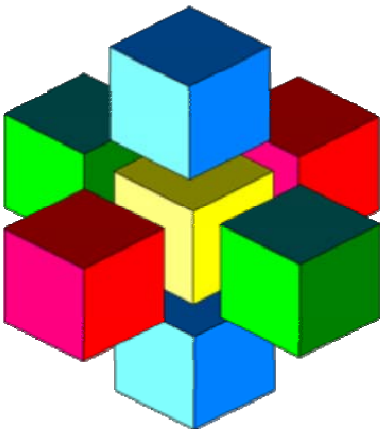

1. First Component: What we do, the project activities.
2. Second Component: For whom we do it, the project beneficiaries or participants.
3. Third Component: By whom we do it, the project staff
4. Fourth Component: With whom we do it, our partners.
5. Fifth Component: At what cost, our budgets.
6. Sixth Component: Where we do it, the places we work.
7. Seventh Component: How effective we are. Our evaluations.

DME-IS needs to be viewed as a collection of basic components each structured in a common framework that will facilitate country office management to consolidate and measure projects progress.

Our current project systems have been built independent of each other and each designed to specific needs. Each project has a different definition on how to count beneficiaries and how to structure information. A project health information system will focus on collecting health information, number of patient visits, number of vaccines, and number of health practitioners trained. An ANR project system will concentrate on collecting data on crops yields, market prices, types of pesticides used. All these systems are serving the specific needs of the project but it becomes impossible for a country office management to be able to consolidate information, as each project defines its own process and components of project information.

Most systems are designed to meet the specific needs of a donor, and focus on collecting sector data and do very little to manage information beyond the scope of the donor's needs. These systems have their own definition and process for collecting and structuring data, projects at a country office spend considerable amounts of resources to develop and manage systems that will not be used beyond the life of the project. As a result the information on the system becomes isolated and difficult to monitor or consolidate.

By focusing on collecting data projects have little time to analyze and use the information internally, even less share it and compare it with other similar projects. Projects collect data that in many occasions is not used or doesn't assist in the evaluation of the project. This excessive focus on data collection has taken us to have the following paradox - **we have the data but we don't have the information.**

DME-IS seeks to resolve the above paradox, we need a more holistic view of project information systems, one that looks at information as an organizational resource and not as a project output. DME-IS approach uses the concept of organizing project data into modules. Each module defines the structure of information that a projects needs to manage. With this approach it becomes feasible for management to consolidate information and monitor project progress. The modules represent the front end view of how a project organizes its information; its back end can consist of more complex systems that feed into the basic module.

4.1 What we do

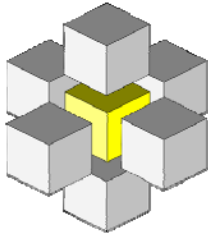

This is the core of DME-IS, its here where all the activities of the project are monitored, includes basic project information and information on the logframe structure. Its from this component that all the connections are made with the other components of DME-IS.

As the central component of DME-IS, and one that defines the relationships among the other modules, it includes information on three different areas:

- General Project Information
- The Project Logframe

4.1.1 Project Information.

Information on the project; identifies the main objective of the project, timelines, donor and beneficiary information, it also includes information on key project stakeholders, name of the project manager, estimated start and end of the project, project type and total amount of funds available to the project. This information is setup at the beginning of the project and requires little or no changes. Provides a high level detail of the project information to all stakeholders.

Information Type	Description
Country Office	Name of the country office were the project will be implemented (CARE Bolivia)
Project Number	Number assigned by RMU and part of Financial System Conventions (BOL622)
Project Acronym	A simple word to easily identify the project (PROMIS)
Project Name	The complete name of the project (Project Management Information System)
Project Start Date	The actual start date of the project per donor contract (Day-Month-Year)
Project Completion Date	The planned end date of the project per donor contract (Day-Month-Year)
Project Final Evaluation Date	Estimated date of project evaluation (Month-year)
Project Manager	Name of manager responsible for the project, include phone, email and or address
Project Main Objective	Describe in a short sentence the main objective

	of the project. That is, the ultimate goal or the impact the project is seeking to achieve.
Project Beneficiaries	Provide a description of the main beneficiaries of the project activities, identify the group or groups
Number of Direct beneficiaries	Detail the total number of beneficiaries.
Project Location	Describe the locations where the project will be implemented. Include distance to main office.
Project Stakeholders	Describe briefly all the project stakeholders
Project Budget	Detail the total project budget in USD currency.

4.1.2 Project Logframe Schedule

This is the part that builds the relationship among all the components of the project. The logframe is built following a direct relationship between the expected outcomes and the planned inputs and activities of the project.

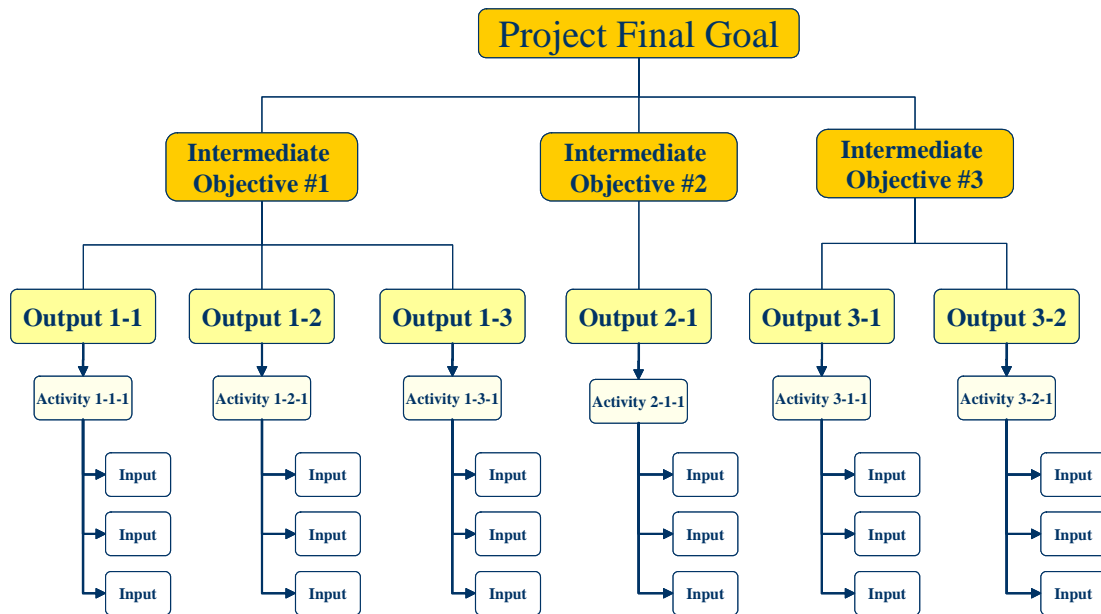

Figure 18 Logframe Schedule

4.1.2.1 Project Goal

Project Final Goal

Information Type	Description
Project Final Goal	Short and simple description of the project goal. (By June of 2007, project beneficiaries will reduce diarrhea infections by 90%)
Statement	A longer description of how the project will achieve the goal.
Indicators of achievement	The indicators that will measure the achievement of the project's goal. (Number of incidents of diarrhea per month), these are the quantitative measures or qualitative judgments to know whether these broad objectives have been achieved.
Means of Verification	The methods or sources of information that exist or can be provided to allow the goal to be measured. (number of incidents reported by the health centers, family surveys).
Baseline value of the indicators	The value that the baseline studies have found. This is the value that the project will be measured against. (2500 cases of Diarrhea reported during baseline, this represents 50% of the target beneficiaries)
Project Goal	The expected value of the indicator at the end of the project. (by the end of the project there will be less than 500 reported cases of diarrhea)
Project Success Factors	Describe how the project stakeholders will determine the project was a success, how will they identify the project met its final goal
Assumptions	All the external factors, to the project, that are necessary to sustain the goal in the long run.
Risks	All the risk the project will face trying to meet the goal.
Indicator Progress	The progress so far of the project, measure obtained during the midterm evaluations.

4.1.2.2 Project Intermediate Objectives

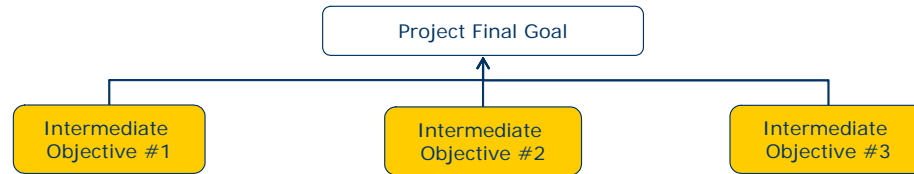

Information Type	Description
Project Intermediate Objective	Short and simple description of the project objectives.
Statement	A longer description of how the project will achieve the Intermediate Objective
Indicators of Achievement	The indicators that will measure the achievement of the project's objectives
Means of Verification	Describe the sources of information that exist or can be provided to allow the achievement of the intermediate objectives to be measured.
Baseline Value of the indicators	The value that the baseline studies have found.
Objective of Project	The value of the indicator that the project aims to achieve
Assumptions	The external factors necessary to contribute to achievement of the goal
Risks	The risks that will jeopardize the achievement of the objective. Factors outside the control of the project
Progress	The progress so far of the project, measure during the midterm evaluations

4.1.2.3 Project Outputs

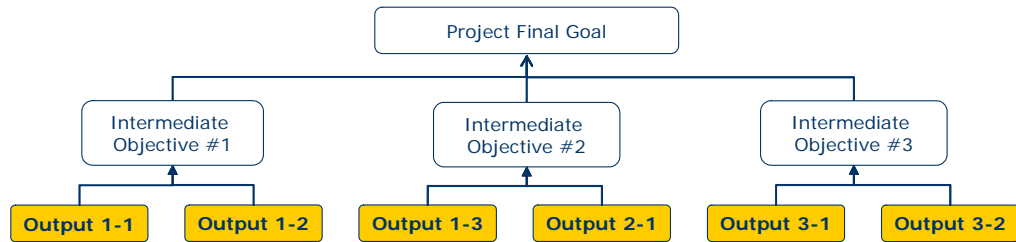

Information Type	Description / Example
Project Outputs	Short and simple description of the project output.
Output Statement	A longer description of the project outputs
Methodology	A description of how the project will achieve the Output
Assumptions	List the factors not in control of the project which are liable to restrict the outputs achieving the purpose.
Risks	List the risk associated with achieving the project outputs
Constraints	List any project constraints to achieve the project outcomes, these may be staff, skills, budget, time, etc.
Expected duration to achieve output	Determine the approximate time required to complete and deliver the output.
Output Goal	Define in quantitative or qualitative terms the goal of the output.
Output Goal Date	Define the approximate date the Output will be completed.
Output Progress to date	Describe the progress to date of the expected Output.

4.1.2.4 Project Activities

All the activities that will result in the expected outcomes.

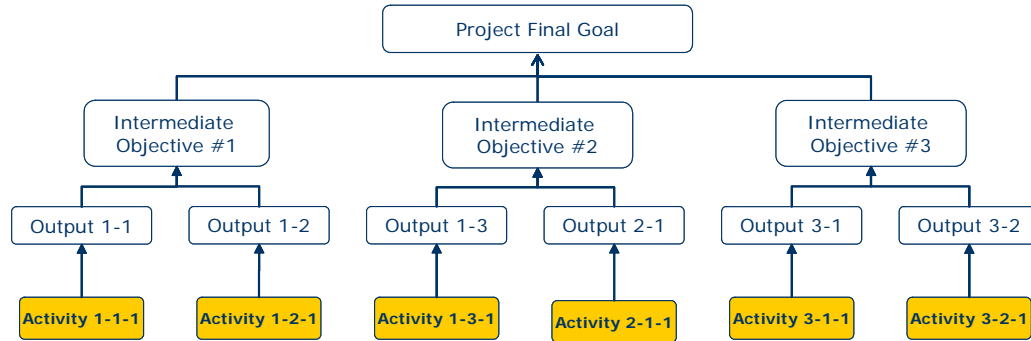

Information Type	Description / Example
Project Activities	Short and simple description of the project activity.
Statement	A longer description of the project activities
Methodology	A description of how the project will carry out the activities
Assumptions	List the factors that will restrict the activities from creating the outputs.
Risks	List the associated risks in delivering the activities
Constraints	List any project constraints to achieve the project activities, these may be staff, skills, budget, time, etc.
Activity Goal Value	Define in quantitative or qualitative terms the goal of the activity. Number of workshops, trainings, water systems, roads, etc.
Expected duration to achieve activity	Determine the expected duration to complete the activity, given all assumptions are correct and all risk manageable
Activity Start and end Date	Determine the expected start and end date to complete the activity.
Activity Progress to date	Describe the progress to date against the expected goal.

4.1.2.5 Project Inputs

The inputs that the project will provide to accomplish the activities.

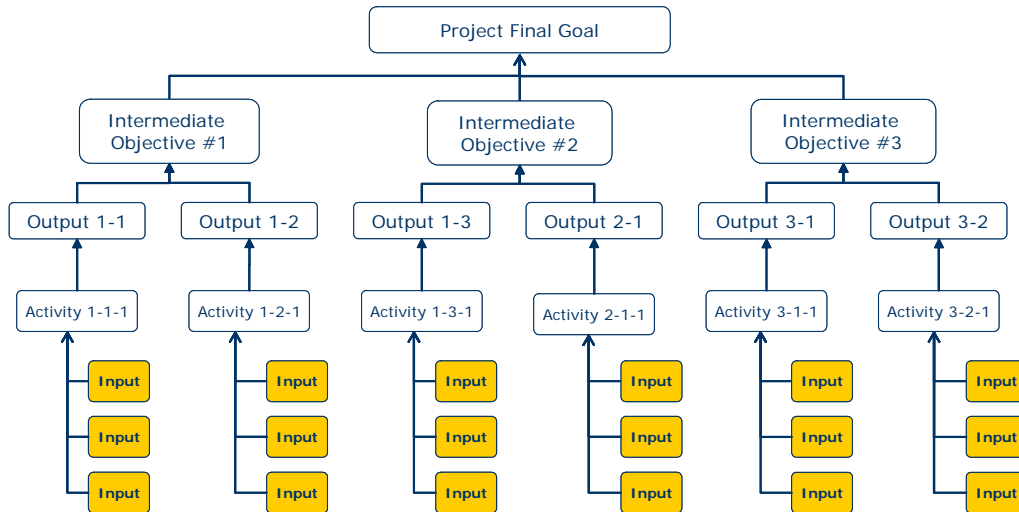

Information Type	Description / Example
Labor	A list of the labor required for the activity, describe the unit of measure, the quantity required, the unit cost and total cost
Material	A list of the material required for the activity, describe the unit of measure, the quantity required, the unit cost and total cost
Equipment	A list of the material required for the activity, describe the unit of measure, the quantity required, the unit cost and total cost
Quality	Describe the quality of the input.
Other Costs	Administration, Internal Cost Recovery, taxes, etc.
Total Cost	Determine the total cost of the input required by the project

Another simple method to capture the cost of each activity is to determine its unit value. For example, to conduct a training session on child nutrition to community members the unit value can be structured as follows:

Activity Name. Training on nutrition methodologies			
Duration of activity: 4 hours			
Location of Activity: Community center (6 hour trip)			
Number of participants: 30 people.			
Material	Quantity	Unit Price	Total
Paper	90	.1	9.0
Pens	30	.3	9.0
Brochures	30	20	600
Equipment	Quantity	Unit Price	Total
Transportation	2	10	20.0
Meals	2	5	10
Personnel	Quantity	Cost per Session	Total
Nutritionist	1	50	50.0
Extentionist	1	40	40.0
Total Cost			728.00

This is the cost per unit to implement the activity. As the project makes progress and more activities are implemented is then easy to figure out the total cost of the objective.

4.1.2.6 Advice for Creating Useful Logframes

- An activity should appear at only one place in the Logframe
- The work content of an output is the sum of the activities below.
- An activity is the responsibility of one only individual even though other staff may be working on it.
- The Logframe must be consistent with the way in which the activities are actually going to be performed.
- The project team should be involved in developing the Logframe to ensure consistency and buy-in
- Each Logframe element must be documented to ensure an accurate understanding of the scope of the work included and work not included in the project.

- The Logframe must be flexible to accommodate inevitable changes while properly maintaining control of the project work.

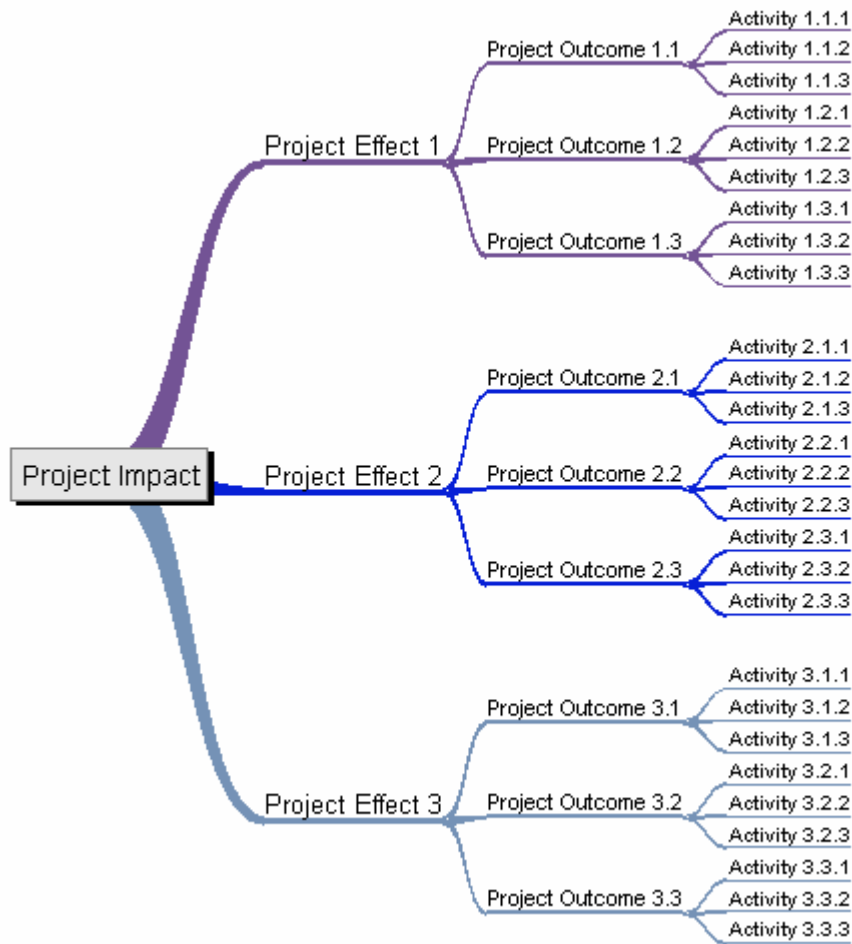
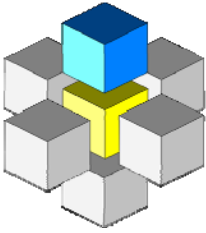

Figure 19 Project's Logframe Schedule

4.2 For Whom we do it



This is information about the project's beneficiaries. The information is basic and seeks to have a general understanding of the beneficiaries demographics, social health, educational and economical information. The information also tries to capture the baseline project indicators defined at the baseline study. Additionally the information will include the issues, challenges, risks and assumptions the project makes on the beneficiaries, as well as information on how the beneficiaries perceive and define the project success, that includes the criteria by which the beneficiaries will define the project was a success or not. Beneficiaries includes families, communities, other groups that will benefit directly by the project's interventions.

4.2.1 Beneficiary Information

Information Type	Description / Example
Beneficiaries	Describe in general terms the beneficiaries of the project
Total number of beneficiaries by:	Men, women , children
Background	Cultural Characteristics of the beneficiary group (languages, religion, social customs, etc.)
Location	Geographic locations of Beneficiaries (states, departments, regions, etc)
Statistics	Basic statistics that describe the major issues facing the beneficiaries:
	Health Indicators
	Education Indicators
	Access to public services (water)
	Economic indicators
	Other Indicators (RBA)
	Languages, religion, etc.
Community Leaders	The names of the leaders in each community of beneficiaries, their role in the project and general contact information (name, address)
Project Success Criteria	Describe how the beneficiaries define the project success.

4.2.2 Beneficiary Analysis

Beneficiary analysis is information to define all the factors that can have an influence on the project success. These include factors that may prevent the beneficiaries to support the project and develop strategies to reduce obstacles.

Information Type	Description / Example
Beneficiary Analysis	The mayor issues affecting the beneficiaries that the project WILL address
	The mayor issues affecting the beneficiaries that the project will NOT address
	Challenges the beneficiaries will face with the project
	Factors that may prevent the beneficiaries from supporting the project
	Strategies to reduce the obstacles for support to the project.

4.2.3 Stakeholders analysis

Stakeholder analysis is a technique used to identify and assess the importance of key people, groups of people, or institutions that may significantly influence the success of your project. The analysis aims to:

- identify the people, groups, and institutions that will influence the project (either positively or negatively)
- anticipate the kind of influence, positive or negative, these groups will have on the project
- develop strategies to get the most effective support possible for your initiative and reduce any obstacles to successful implementation of the project.

Stakeholder	Interest in the Project	Assessment of Impact	Potential strategies for obtaining support or reducing obstacles
Donor			
Beneficiaries			
Management			
Local NGOs			
Local Organizations			
Local Government			

1. Organize group brainstorming. Identify all the people, groups, and institutions that will affect or be affected by your initiative and list them in the column under "Stakeholder."
2. Once you have a list of all potential stakeholders, review the list and identify the specific interests these stakeholders have in your project. Consider issues like: the project's benefit(s) to the stakeholder; the changes that the project might require the stakeholder to make; and the project activities that might cause damage or conflict for the stakeholder. Record these under the column "Stakeholder Interest(s) in the Project."
3. Now review each stakeholder listed in column one. Ask the question: how important are the stakeholder's interests to the success of the proposed project? Consider:
 - The role the key stakeholder must play for the project to be successful, and the likelihood that the stakeholder will play this role
 - The likelihood and impact of a stakeholder's negative response to the project

Assign A for extremely important, B for fairly important, and C for not very important. Record these letters in the column entitled "Assessment of Impact."

4. The final step is to consider the things that you could do to get stakeholder support and reduce opposition. Consider how you might approach each of the stakeholders. What kind of information will they need? How important is it to involve the stakeholder in the planning process? Are there other groups or individuals that might influence the stakeholder to support your initiative? Record your strategies for obtaining support or reducing obstacles to your project in the last column in the matrix.¹³

¹³ *The Guide to Managing for Quality* Copyright 1998 [MSH](#) and [UNICEF](#)

4.3 By Whom we do it

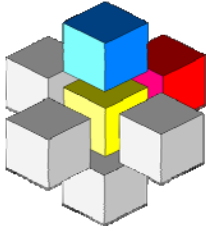

Information on CARE's project staff dedicated to manage and execute the project activities. This information is complementary to the information captured by the HR systems and seeks to inform project stakeholders on the skills, responsibilities, and roles of CARE's staff in the project.

BY managing project staff information, the project can better understand the relationships and collaboration required to accomplish the project goals. This information can help clarify the roles of all members in the project and can also help in the resolution of conflicts and specially help in identifying redundancies and omissions.

4.3.1 Project Staff Information

Information Type	Description / Example
Project Manager	Name
	Phone number
	Home Address (for emergency needs)
	Email
	Technical and Managerial Skills
	Responsibilities in the project
Project Staff	Name
	Phone number
	Home Address (for emergency needs)
	Email
	Technical Skills
	Roles and responsibilities in the project
Project Training requirements	List the training the project staff will receive during the project to fill knowledge gaps

4.3.2 Project Staff Assignments

This section defines the activities that each one of the project members will be responsible. The activities assigned come from the list of activities planned in the Logframe and can be assigned either by output or by activity.

Project Staff	Assignment	Time	Place
Coordinator	Output 3.1	Start and end	Location
Technical	Activity 3.3.1,2,3	Start and end	Location
Coordinator	Output 1.1	Start and end	Location

Technical	Activity 1.1.1,2	Start and end	Location
Technical	Activity 1.1.2,3	Start and end	Location

Project assignments are planned by the project team on a quarterly basis and define the activities and locations where the activities will take place. The assignment identifies the type of work a project staff has to deliver in the planned time, and this is used to feed information on the project progress reports. Upon completion of the activity project staff report back to management any delays or issues the activity faced, these may include reasons why the activity was not completed and an estimate the date of its completion.

Example Project Activity Assignment Sheet

Staff Names	Activity	Start	End
Name of staff responsible for carrying out the activity. (either project or partner staff)	Name of Activity (code)	Start Date Actual Start Date	End Date Actual End date
	Location	City	State
	Location(s) of the activity (name of village)	City or town	Department or subdivision
	Beneficiaries	Actual	Percentage
	Expected Number of participants	Actual Number of participants	Actual/Expected
	Approach	How	Inputs
	What will be accomplished.	How it will be accomplished	Inputs required
	Results	Causes	Lessons
Describe the final results of the activity.	Describe the causes that the kept from completing the activity	Lessons learned during this engagement	

The assignment sheet can take many forms, the important information is to clearly define responsibility for an activity and an expected timeframe for its completion.

4.3.3 Project Organizational Chart

This chart helps the management and supervision of project staff assigned to the project. The chart can also include staff from other partner organizations that are working for the project.

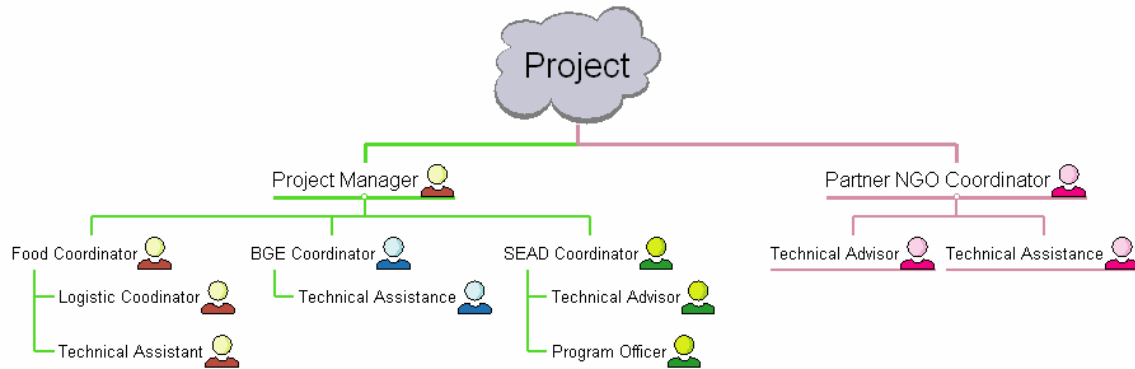

Figure 20 Project Org Chart

4.3.4 Project Organigraph¹⁴

Although an org chart is a good tool to know who supervises who, it does little or nothing to explain how the project staff actually works. An organigraph is a non-traditional method of graphically showing how a project works. Instead of showing the hierarchy of a project by its positions, it actually depicts actions, methods, processes for managing, or delivering a service. While the org chart only shows who reports to who and who is higher on the evaluation scale, it really provides no valuable information as to what goes on every work day. The organigraph describes the work that project staff need to coordinate among themselves and with other project stakeholders, it shows information on the critical project activities each member is responsible for and increases the collaboration efforts.

¹⁴ Mintzberg, H., and Van der Heyden, L. "Organigraphs: Drawing how companies really work," in *Harvard Business Review*, September-October 1999, pp. 87-94

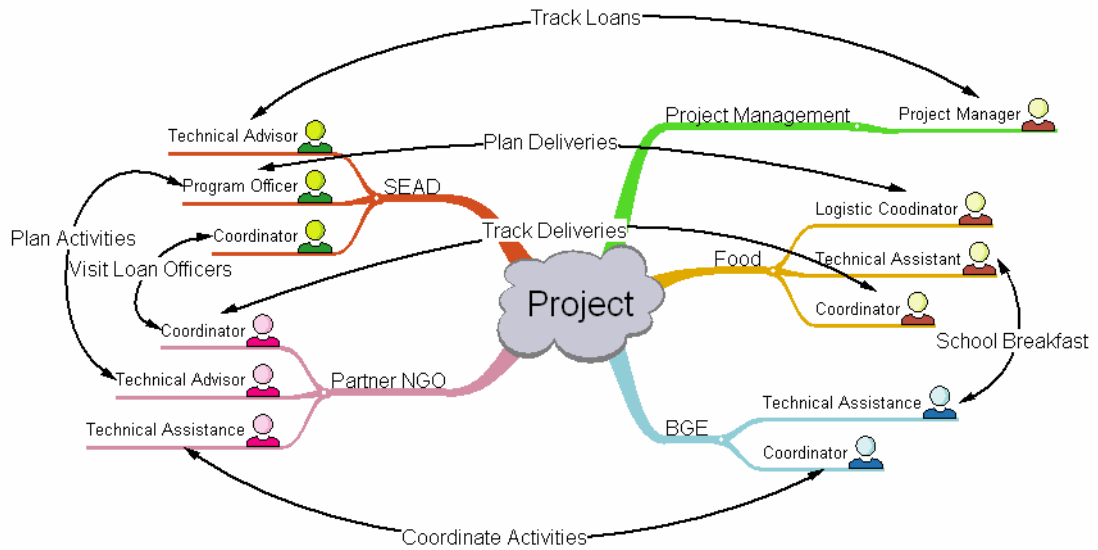

Figure 21 Project Organigraph

Another view of the project organigraph is used to understand the relationships that exist among project stakeholders. Here the purpose is to draw a line between one person and all the people he or she has a working relationship, independent of rank. The idea is to see who are the people that have the most connections and thus make them “hubs” for information networks. These are the people that are most likely to succeed when the project needs them to start a change or disseminate information.

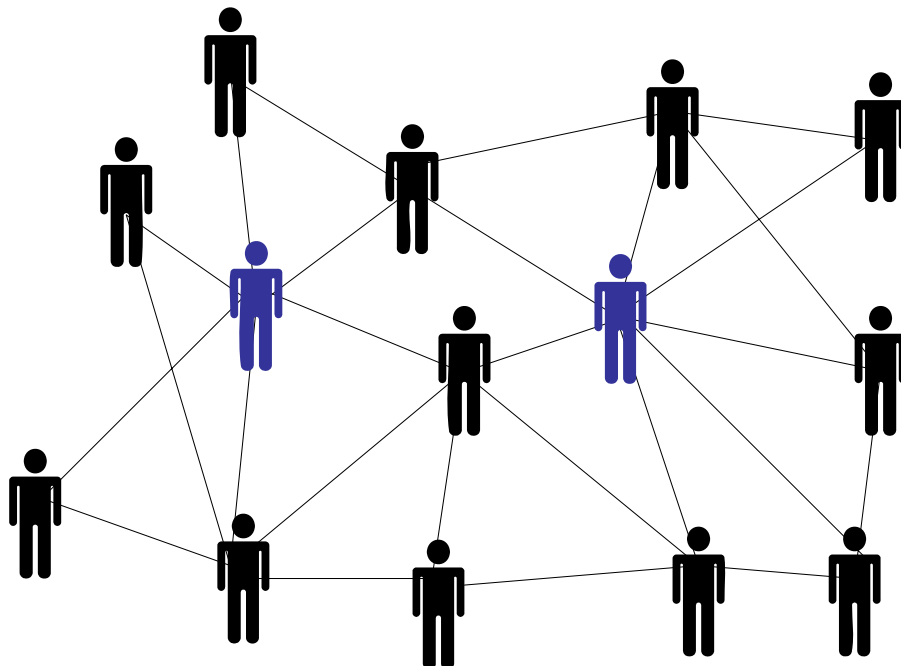

Figure 22 Project Organigraph, Networks

4.3.5 Project Working Matrix

Another tool to help in the definition of levels of collaboration is the development of a matrix or a table that shows the level of interdependencies that exists among the different project stakeholders.

		Level of Collaboration				
		Staff A	Staff B	Staff C	Staff D	Staff E
Level of Coordination	Staff A		A	B	B	B
	Staff B	1		A	B	B
	Staff C	1	2		C	C
	Staff D	2	3	1		C
	Staff E	2	3	2	3	

Collaboration. As defined collaboration is the mutually beneficial well-defined relationship entered into by two or more organizations or project members to achieve common goals. Collaboration is the process of various individuals, groups, or systems working together but at a significantly higher degree than through coordination or cooperation. Collaboration typically involves joint planning, shared resources, and joint resource management. Collaboration occurs through shared understanding of the issues, open communication, mutual trust, and tolerance of differing points of view. To collaborate is to “co-labor.”

Levels of Collaboration:

A. High, requires close relationships, constant exchange of information, structured and planned activities for collaboration to occur. Requires a high level of trust, within the collaboration process, each party fulfills a carefully defined role; comprehensive planning is required; leadership, resources, risk, and control are shared; and the working relationship extends over a relatively long period of time for common goals.

B. Medium, less structured, around a few project areas or themes, less formal and less supervision.

C. Low, collaboration is had-oc, on occasional basis on specific project areas, informal and loose.

Coordination. Coordination includes activities between two or more project members or organizations that has as its purpose prevention of duplication of efforts and assurance of provision of service

Levels of Coordination

1. High, Uses of common schedules and specifications for the delivery of activities. Use of policies and procedures to ensure close coordination during the life of the project
2. Medium, only for specific deliverables or activities in the project and for specific activities
3. Low, less formal, may occur for specific deliverables that have low impact to the project.

4.3.6 Project Roles and Responsibilities

Another tool to help the coordination and collaboration is to detail all the roles and responsibilities of all the people involved in the project, these need to include key stakeholders and other people that will have a direct participation in the project

Project Role	Name	Main Responsibilities	Major Deliverables	Support required	Comments
DME-Coordinator	Name	Information analysis. M&E. Staff training	Plans and evaluations	Project and Program Manager	

Example of a Project Roles and Responsibilities matrix

4.4 With whom we do it

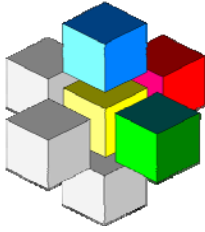

This section describes all the people that will participate and provide input to the project. These are the partners and other project stakeholders who will deliver goods or services to the project beneficiaries. The information is for internal use of the project and has the purpose to detail a map on the strengths, weaknesses, opportunities and risks of each one of the project's partners. This information helps the management of the project in identifying risks.

4.4.1 Partner Information

Partner	Contact	Stake in the project	Risk in the project	Value to the project
Name of the partner	Contact name, address	What they gain from the project	What they lose if the project doesn't deliver what they need	What they bring to the project that adds value

4.4.2 Partner Analysis

For each partner evaluate its strengths, weaknesses, opportunities and risks associated with them. The analysis will provide a clearer picture of the partner's ability to deliver the work as defined by the project and the donors. The project will then identify and develop strategies to compensate the shortcomings or leverage the advantages of the partnership.

Strengths	Weaknesses	Opportunities	Risks
The strengths they bring to the project	The weaknesses and areas that may hinder the project. Areas that the partner needs to improve	The strategic advantage and value of having this partner	The risk and threats to the project outcome if the weaknesses are not dealt with

4.5 At what cost?



All projects need resources, and financial resources are among the most important for development projects. A careful planning of project costs and expenditures can be a significant factor for the success of the project. A project manager is ultimately responsible for the project budget, especially in using these resources wisely to meet the desired objectives. An important piece of information for a project manager comes from the project expense reports, they provide a detailed view of where the project is in terms of its cost and that can help determine whether or not the project can complete all its planned activities.

4.5.1 Budget Development

There are two approaches to develop a budget, top-down is when you already have a lump sum figure and you need to figure out the number of activities and number of beneficiaries you can do with the budget assigned. The bottom-up is to determine the cost of how much a project will cost based on the required activities and number of beneficiaries. In any case all activities should have an estimate of the cost required to complete them. This initial estimate can then be used to develop the final project budget using financial codes from the chart of accounts.

The purpose of having the project budget broken down by activity is to help in the analysis of project progress and determine if the project is meeting its goals on time and within budget. A common problem for project managers is to find out at nearly the conclusion of the project that they either have no money to complete the planned activities or that there will be an excess of funds that the project will not be able to spend and may need to be returned to the donor.

4.5.2 Budget Information

With budget information broken down by activity, the project manager can easily verify how the physical progress of the project, from the project schedule, matches the project budget plans and actual expenditures.

Activity	Output	Labor Cost	Material Cost	Other Costs...	Total Cost
1.1.5. Capacity Building in RBA, at location BO-01	20 project staff trained	2,500	1,540	2,000	5,040

With this type of information the project can organize its budget following the initial project logframe. What this means for the project manager is the ability to track and measure the cost of the project by the outputs it has produced. This is quite useful at the time of project evaluation to determine the actual cost of the project impact or the cost that the project incurred in order to meet a desired goal.

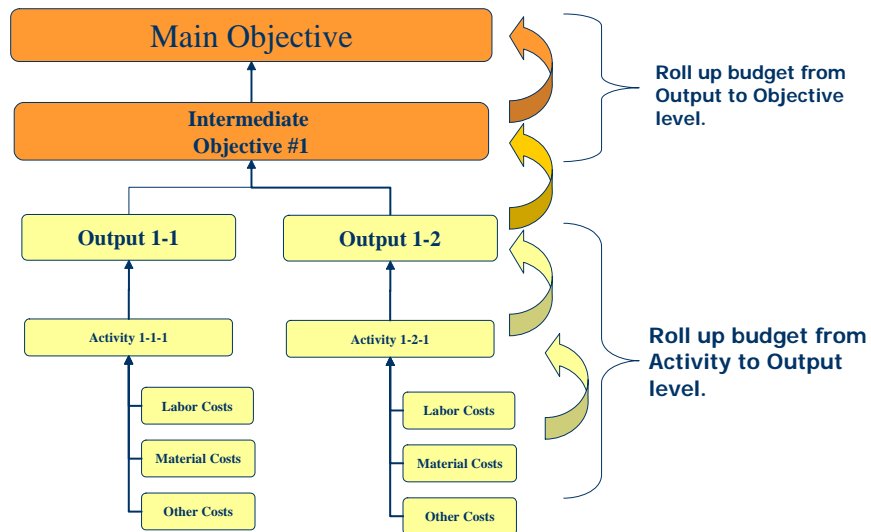

Figure 23 Project Budget and the Logframe Schedule

4.5.3 Budget Analysis

A simple method to analyze the progress of a project against the planned and actual budget is to chart the information. The chart below shows a line for the planned budget and another for the actual expenses, the difference shows whether the project is under or over budget. Under spending is when we ask for money that we are not spending fast enough, this can be caused by a slow start of the project. Overspending means that we are spending money faster than what we are receiving from the donor, the implications can be additional cost to the Country Office who may be forced to use unrestricted funds and restricting the cash flow for the entire mission.

Every project has a natural cycle that defines how money will be used during a year, a project based on historical data can try to accommodate its budget expenditure plan to this natural cycle and thus avoid the cost associated with under spending or over-spending.

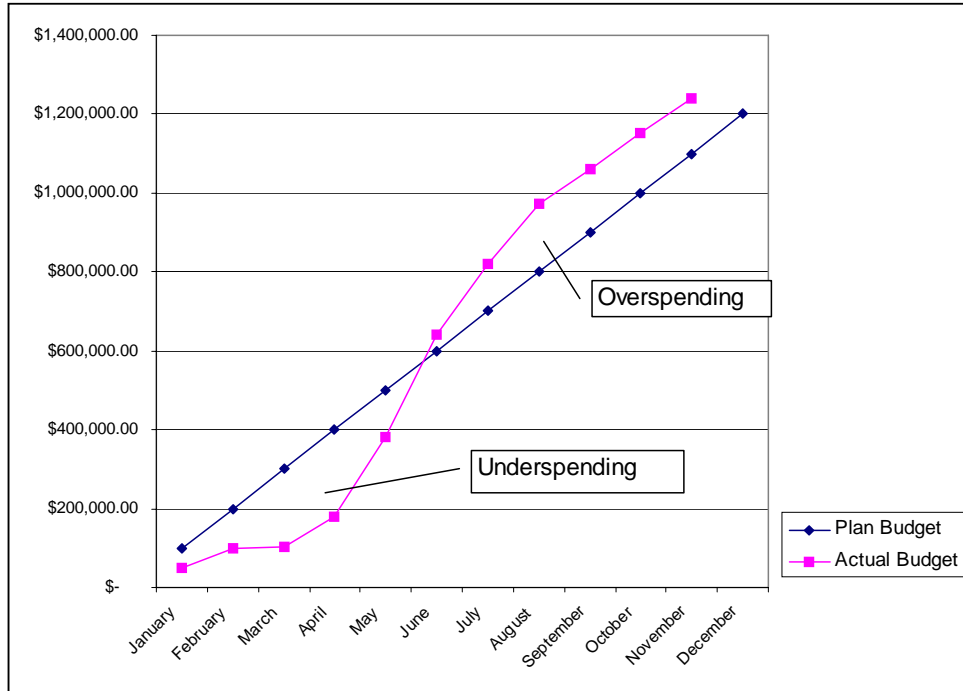

Figure 24 Project Budget Chart

4.5.4 Budget Monitoring

At the end of a cycle, a month or a quarter, the project needs to evaluate its project budget to determine if the project is on track and that its financial resources are being used accordingly. To accomplish this the project manager can use a simple process:

Example. a 12 month project is in its 4th month, has accomplished 25% of its activities but has spent 41% of its financial resources according to the latest financial report. The project is at 33% planned progress. How can a project manager know if his project is on track or not?. Total cost of the projects is \$1,200,000

Month 1	Month 2	Month 3	Month 4	Month 5	Month 6	Month 7	Month 8	Month 9	Month 10	Month 11	Month 12
Activity 1	Activity 2	Activity 3	Activity 4	Activity 5	Activity 6	Activity 7	Activity 8	Activity 9	Activity 10	Activity 11	Activity 12
\$100,000	\$100,000	\$100,000	\$100,000	\$100,000	\$100,000	\$100,000	\$100,000	\$100,000	\$100,000	\$100,000	\$100,000

First the PM will need to do a basic analysis,

- A. The cost of activities planned in the 4th month is \$400,000 (33% x 1,200,000), i.e. what we should have spent based on plans. Or Budgeted Cost of Work Scheduled - BCWS
- B. The actual cost of activities completed is \$500,000 (from financial reports). The actual expenditures on month 4. Or Actual Cost of Work Performed - ACWP
- C. The cost of activities delivered is \$300,000 (25% x 1,200,000), the cost of all activities completed to date. Or Budgeted Cost of Work Performed - BCWP

The above elements are part of the Earned Value analysis; Earned Value is a performance measurement that compares the amount of activities (work) that was planned with what was actually performed to determine if cost and schedule are proceeding as planned.

To know whether or not the project is on schedule calculate the following:

Schedule Variance (SV) = BCWP – BCWS , SV = \$300,000 - \$400,00 = (\$100,000). A negative number means the project is behind schedule.

Another way to calculate the variance is by the Schedule Variance Index or SVI = BCWP/BCWS, SVI = \$300,000/\$400,00 = 0.75, a value less than 1 means the project is behind schedule.

To know whether or not the project is on budget calculate the following:

Cost Variance (CV) = BCWP –ACWP (or the difference between the budgeted costs and the actual costs. For this example. CV = \$300,000 - \$500,000 = (\$200,000). The negative result indicates a budget overrun. Another way is by the Cost Variance Index (CVI) = BCWP/ACWP, = \$300,000/\$500,000 = 0.6. A value less than one means the project has a budget overrun, in other words the project has spent more money that the value of the activities delivered to date.

4.5.5 Budget Recommendations

Here are some basic tips to help you when designing your project budget

- Take your time and ask as many people as needed. Estimates should not be made in a hurry, as they tend to be highly inaccurate. Include staff from finance to double check your assumptions
- Document your work. It is easier to review and eventually verify your calculations if you write down the process you used to get the estimate.
- Estimates should be budgeted slightly higher than originally calculated. It is better to be pessimistic than overly optimistic.
- When your project involves transactions in currencies other than your own national currency, a higher uncertainty and risk is given when exchange rates vary. If you don't have the option to include safeguards or obtain all quotations in your local currency, it usually is a matter of skill, judgment and foresight to keep the risks to a minimum.
- It has become common practice in project cost estimation to nominate one currency as the control currency for the project, and then to convert all estimated costs into that currency using carefully chosen exchange rates.
- Depending on the level of risk in the project, many project managers add a certain percentage to the budget for unforeseeable expenses.

4.6 Where we do it?



The purpose of this component of DME-IS is to facilitate management when the project is required to work in different locations. A Geographic Information System (GIS) is nothing but the visualization of information on a map. The map can include information on natural conditions, rivers, mountains, roads, lakes, etc. The information is available from many sources and the project will need to identify the type of information it is best suited for the project needs. A simple approach to GIS can improve the management of the project's logistics and delivery strategies.

A GIS needs to start at the country level, and then (according to each country's own parameters) define each political subdivision that will eventually pinpoint the area where the project beneficiaries are located.

GIS country information can also be a powerful tool to identify potential areas where the project can either have increased risks or increased benefits. It helps track progress in a country and match it against other GIS maintained by the government or international agencies. A GIS can also become a tool to help in the development of project proposal to donors.

There is no need to use complex and expensive computer based applications for GIS. Unless the donor requires it, a project can develop a simple GIS that is partially manual and partially computerized that can meet the needs for the geographically representation of information. Again the goal here is to see, from a different perspective, the implications of managing a project that needs to work on a wider geographical area.

A GIS can help by making or discovering connections between activities based on geographic proximity; looking at data geographically can often suggest new insights, explanations. These connections are often unrecognized without GIS, but can be vital to understanding and managing activities and resources.

4.6.1 Geographical Information

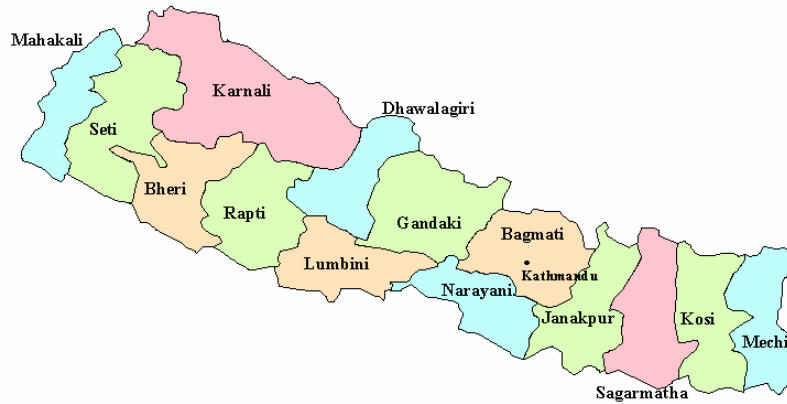

Information Type	Description / Example
Country	Name of Country
Region or Department	First Subdivision, name
Zones	Second Subdivision, name
City	Third Subdivision, name
Town or Village	Fourth Subdivision, name

Examples of GIS maps with country information:

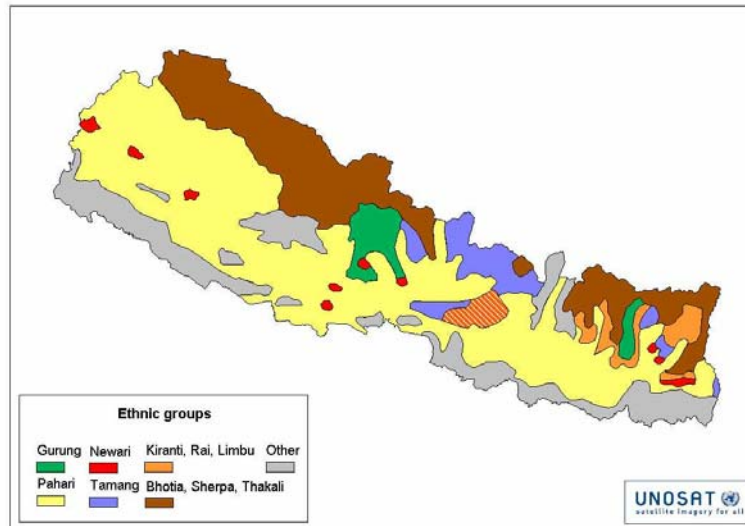

Figure 25 Ethnic Groups

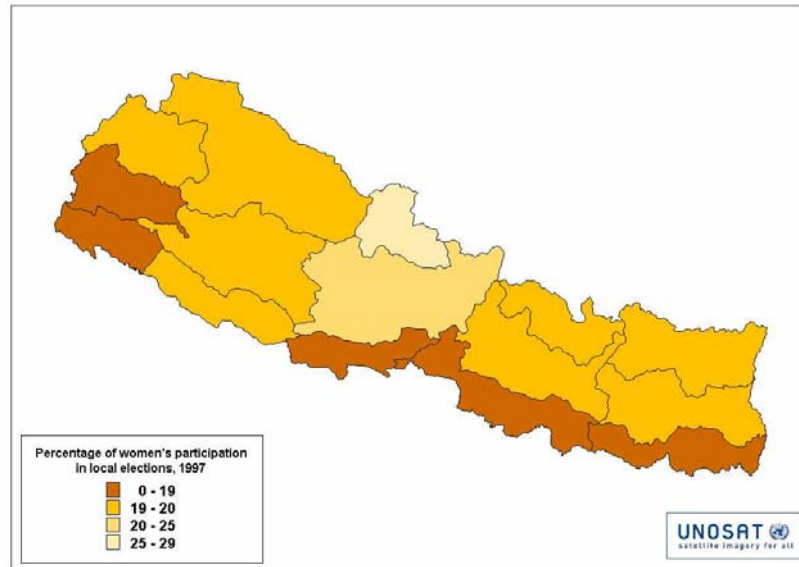

Figure 26 Women's Participation in Local Elections

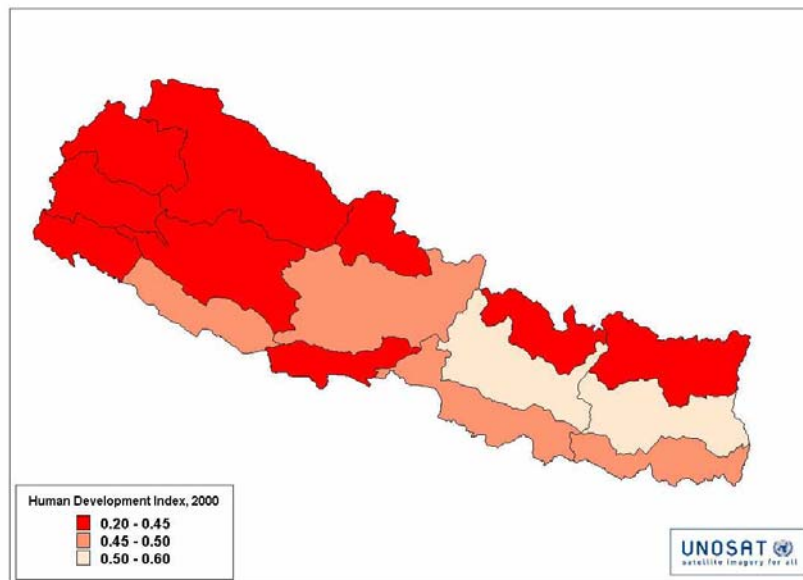

Figure 27 Human Development Index 2000

4.7 How effective we are



A final component of the DME-IS is the way information on project's baseline and evaluations are managed. The project needs to have a structure to manage this information from the beginning of the project until its very end. Only by the analysis of the project outcomes against its expected objectives we are able to know whether or not the project was a success.

4.7.1 Evaluation Information.

Evaluation information has many elements; the first one is information on the Baseline, the baseline provides with a “snapshot” of the situation of the project targets at the beginning of the project and it serves as a tool to compare the progress made by the project during and at completion. Midterm evaluations are made half way through the project, basically it's a small stop in the project to see whether or not the project is in the right course. Internal Project evaluations are done by the project staff to evaluate not only progress made but to see if any changes are required in both the goals originally planned or the methodologies to implement the activities. The final evaluation seeks to answer the questions. Did the project meet its expected objectives?

Information Type	Description / Example
Baseline	When deciding what information to collect for a particular indicator, the projects needs to ask if the information collected can be used to measure and make comparisons on progress or not. Project suffer from either getting too much or too little information.
Internal Evaluation	Made by the project before the midterm evaluation to determine progress or deviations from plans. This information can be quite useful for the midterm evaluation and can result in the discovery of opportunities to improve the project.
Midterm Internal Evaluation	Midterm evaluation, usually made by the donor agency. Made by the project before the midterm evaluation to determine progress or deviations from plans. This information can be quite useful for the midterm evaluation and can result in the discovery of opportunities to improve the project.
Final Evaluation	Final evaluation, usually made by the donor agency.

The DME-IS needs to be able to collect in an organized manner the information gathered by the evaluation process. Some of the common toll used for data collections in evaluation are:¹⁵

- Surveys
- Participatory Rapid Assessment
- Key Informant Reviewers
- Focus Group Discussions
- Individual and Household Case Studies

The DME-IS system needs to be designed taking in consideration the information needs of the evaluation process and the ability to show data when needed.

How effective we are should not only respond on how the project was able to deliver all activities but also how efficient we were in delivering within the boundaries of the schedule and the budget and how the project deliverables met the project objectives. It is not uncommon for a project to have completed all activities on scheduled and under budget but have missed completely the objective of the project.

4.7.2 Lessons Learned

This is an area that the project uses to capture the lesson they are learning on the project, information that can help in the re-design of the project or in the design of new projects.

The rationale behind capturing lesson learned is driven by the very same nature of projects: projects as such are undertaken to create a unique outcome, or result. Since each project is unique, it is impossible to predict the exact course of the project with precision. Therefore each project is expected to face a unique set of challenges. But while the set of challenges is unique, individual challenges recur. By documenting the causes of variances, and the thinking behind the corrective action, we can enhance our ability to respond to future project challenges. We enhance our ability to deliver every project on time, within budget, according to specifications and contractual agreements.

¹⁵ CARE Project Design Handbook, Richard Caldwell, July 2002



Chapter 5 Information Environment

5

5. INFORMATION ENVIRONMENT

" information management is 5% technology and 95% psychology" Tom Peters

Information lives in an ever changing environment that has direct effect and influence on its context, meaning and purpose. To understand information a project needs to look beyond the concept that information is a collection of data and start looking at information within a much wider and holistic context. Information is also a system of people, practices, values, and technologies in a particular local environment. In this environment, the attention is not on systems, but on human activities that are served by systems. Information environment introduces the notion of locality that is missing from the system view, Information lives in an environment with complex dynamics where change is systemic; when one element changes its effects can be felt throughout the whole system. The environment consist of the numerous interacting and interdependent social, cultural and political subsystems that shape the creation, flow and use of information. This environment influences what information is collected, how it is organized, stored, what information is made available and to whom, and what information is valuable and which is not.

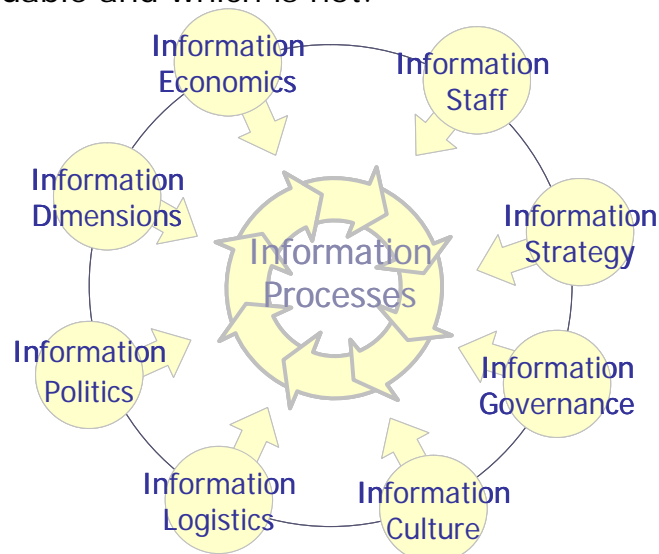

Figure 28 Information Environment

A key element of managing information is the recognition that is not just a matter of "processing" information. Information management depends on exploiting the information resources to the fullest. For this to happen a project needs to adopt a holistic approach to information management, an approach that takes in consideration an environment that has a direct impact on information and one that consist of the following factors:

For projects to be successful in information management, a careful analysis is required on how the elements of the information environment need to be treated. It is not enough to see information as a product, we need to treat information from all the dimensions that are affected by the organization and avoid "tunnel vision" solutions, specially an understanding of the critical social networks in which information and knowledge are always a part of.

An information environment puts people at the center and systems and technology as an enabler. It has to do more with managing human behaviors than managing technology.

5.1 Information Economics

Managing information has a cost, and in many occasions this cost is not properly measured. A project can spent considerable amount of financial resources and time to collect data that will not be used or information that will have little or not relevance to the project objectives.

A project needs to evaluate the cost to identify, acquiring, store, disseminate and use each one of the information products it will deliver. From this perspective a project manager can view information as an investment made to improve the decision making process. If the information collected does not lead to a decision, then the project needs to determine if it's worth collecting it at all. Unnecessary duplication can be avoided, and common standards can reduce costs and difficulties.

A project manager needs to measure and plan for all these costs and evaluate if the final results are worth the cost and efforts.

Information Steps	Quantity needed	Staff	Material	Other Costs	Total Costs
Baseline Surveys					
Design of Beneficiary Surveys					

Training to staff in collecting data					
Copies of forms to collect information					
Travel to communities					
Collection and Compilation of data					
Analysis of data results					
Report to Donor and management on results					
Print and send report					
Archive report					

5.2 Information Dimensions

Information lives in an environment that needs to be defined beyond its basic representations. Information deals with other elements that help define its relevance to the project objectives. Some of these elements are as follows:

5.2.1 Types of information

Provides categories that are used to structure or analyze information. Given a piece of information it answers the simple question: what type of information are we dealing with? Information categories or types of information include, but are not limited to:

○ Beneficiary Information	○ Project Information
○ Country Geographical Information	○ Donor Information
○ Country Population Information	○ Expert Domain Information
○ Country Economical Information	○ Partner information
○ Country legislative Information	○ Other NGOs information
○ Country Health Information	○ Country Cultural Information
○ Political Environment Information	○ Financial Resources Information
○ Local Government Information	○ Market Information

o Community Information	o Weather Information
-------------------------	-----------------------

All these are elements that a projects needs to consider in designing its information management plan. All these types of information will have an impact to the project and they need to be considered and made available to the project stakeholders.

5.2.2 Levels of understanding

Explains how project staff discovers meaning in data, and helps develop an ability to interpret and use information. Questions that a projects needs to ask include:

- What understanding do we have of this information?
- Is there a single definition, or are there alternative definitions in use?
- Do we have definitions of the component parts of the information
- What background knowledge can help us make the most effective use of information?
- How did we interpreted and used this type of information in the past?

5.2.3 Types of representation

Is about how information is presented, presenting the same information in different ways can suggest totally new meanings or reveal hidden patterns. Some of the main questions here include:

- How is the information represented or stored?
- How is the information structured?
- Is it possible to structure it differently?
- What are the needs of information users?
- Do all users can interpret the information the way it is presented?

5.2.4 Levels of transition

Is about changes that might happen to the information over time. Questions associated with levels of transition include:

- Is the information undergoing any form of transition?

- Is it likely to change in the future?
- Has it changed in the past?
- Will it be redesigned or restructured in any way?
- If so, what is the impact on us?
- Does this create any new opportunities?

5.2.5 Levels of responsibility

Is about making sure that someone takes responsibility for the key actions on information, such as creating, distributing, or developing it. Resources are always more valuable when someone takes on the appropriate responsibilities for looking after them! This includes such questions as:

- Who owns or controls the information?
- Who is responsible for collecting all the information?
- Who is responsible for the accuracy or quality of the information?
- Who is responsible for analyzing the information
- Who is responsible for distributing the information?

5.3 Information Logistics.

Logistic is defined as the “right information at the right time and place and to the right people”. A project can be successful in identifying and collecting data but its efforts will be in vain if it fails to make the right information available to those who need it at the time they need it. Users of information need to receive detailed information free of related facts, the right information means information that is relevant to support decision making.

Information needs to be available at the right time, information that is obsolete or late does not help management or donors. Information should be made available to all project stakeholders, depending on priority and situation, with a flexible format customized to each user’s need and capacity to access and interpret the information.

The main objective and concern of information logistics is to supply information to all users, not just data but the information that users need, when they need it and in a format that is useful to use.

5.4 Information Staff

All project staff are responsible for managing information, whether is collecting, storing, analyzing, reporting or using information. Their role in the overall information management process is critical to the project. Project staff, including partners are individually and collectively responsible for determining what should be done with the information, and how and when this should be accomplished. In this sense, they are all managers. Each of them has a key role for the success of the project, information management is not the sole responsibility of a DME officer or project manager; it's the responsibility of all project stakeholders.

The key responsibilities of all information staff are to make information meaningful, accurate, timely, accessible and engaging. In order to achieve this project staff needs to develop information skills required to manage information as a resource, an organizational resource used to make better decisions, improve the impact of our work, inform our stakeholders and take action. The skills required are similar to the skills needed to manage financial or human resources and are used to obtain the most benefit from the information resources the project and the organization creates.

5.4.1 The basic skills required

- Ability to articulate ideas clearly in writing and words;
- Understanding the principles and practices of information management.
- Exercise informed judgment to meet the information needs of the project stakeholders.
- Have an understanding of social, political and ethical issues related to information sharing.
- Use, implement and manage appropriate technology in the development of information services.
- Have an awareness of the organizational context in which information is used.
- Have an ability to instruct and train others in the use of information based systems.

- Have an ability to foster a `community space` that provides a venue for information exchange.
- Can market their knowledge and skills throughout an organizational structure.

5.4.2 The personal qualities required

- Effective communication with information users;
- An ability to organize information in a systematic and logical way;
- Curiosity and enjoyment in finding information;
- A creative approach to problem solving;
- An ability to analyze and interpret information

5.4.3 CARE competencies for information management¹⁶

- Determine what information needs to be collected and/or monitored in order to manage the project effectively. Look for information that will require some action or planning on your part.
- Scan the information regularly and identify anything you need to act on. Make a habit of communicating the information to others who will be affected by it.
- Decide how often you need this information: Is it daily, weekly, or monthly?
- Determine what external information needs to be tracked, for example, changes in CARE policy, economic or political trends affecting your customers or donors, new technical developments like a new computer system at CARE or changes on the internet. Decide whether the information is useful as it is, or if it needs to be summarized in some way.
- Decide how the information should be stored so that you and others will be able to find and use it easily.

¹⁶ CARE competencies manual

5.5 Information Standards and Principles

5.5.1 Value of information

Project information is an essential tool in the design, delivery and evaluation of effective programmatic interventions, and in the assessment of the project status against its desired outcomes. Project information is a valuable organizational asset that needs to be properly managed. Project staff should manage all information resources as strategic assets which support effective decision-making, meet operational requirements and protect the legal, financial, and other interests of donors, project stakeholders and the beneficiaries.

5.5.2 Purpose

Project information is collected and used on a "need to know" basis. The purposes for collection of, and access to, information include the needs of donors, managers, partners and other project stakeholders for information required to make the best possible decisions.

5.5.3 Respect for privacy and dignity of the individual

Collection and of project information are guided by a commitment to ensure confidentiality of project participants information and a reasonable expectation of personal privacy. Because of this commitment, privacy safeguards for project beneficiaries are an essential element in the design of information systems. Individuals have a right in some circumstances to refuse to give or to limit use of information about themselves, and individuals should be informed of this right.

5.5.4 Openness

Wherever possible, information should be collected directly from the individual or original source of the information. The collection and use of project information should be characterized by transparency so that it is clear to the provider and the collector why the information is being collected, how it will be used and who will have access to it.

Whenever feasible, the collection and use of project information is characterized by consent from the person about whom the information is collected. Project beneficiaries have a right to re-

view records of their personal information. Beneficiaries have a right to know what personal information is collected about them by the project and how it is used. There must be no personal record-keeping system whose existence is secret.

5.5.5 Accountability

A project is responsible for safeguarding and controlling the information entrusted to its care and is answerable to proper authority for the loss or misuse of that information. The project has to inform donors and projects stakeholders of the manner in which project information is used and the information provided should be traceable back to the original data collected.

5.5.6 Confidentiality and Security

A project must ensure that information is not disclosed to unauthorized persons, processes, or agencies. The project is responsible for the protection of sensitive information from unauthorized disclosure to third parties. The treating of information as private and not for distribution beyond specifically identified individuals or organizations as defined by the project stakeholders. Personal beneficiary information must be treated with respect and only used within the objectives of the project.

5.5.7 Integrity

The primary purpose for the collection and use of project information is to benefit beneficiaries by improving the project interventions. Integrity provides verification that the original contents of information have not been altered or corrupted and that managers can be confident on the quality of the information to make decisions on the project. A project shall make reasonable effort to ensure that all information is accurate and up-to-date and that procedures are in place to dispose of records once they are of no further use.

5.5.8 Timely and Accurate

Information must be timely and accurate; a project is responsible to meet the needs of management, donors and other projects stakeholders who need the right information at the right time.

5.6 Information Strategy

An effective Information Strategy will ensure that investments in information, information technology, systems and services is efficient and effective; and that information produced within the organization is exploited to the benefit of the organization.

The Information Strategy must flow from the Strategic Plan of the organization and help achieve its mission. As such, it is a tool for management, a means by which changes can be brought about, and attitudes and culture amended. It enables management to take account of the views of other members of the organization (staff and donors). An Information Strategy is also a means to build better development strategies.

The Information Strategy exists to support the project's objectives. It aims to do this by facilitating enquiry, planning and management. The Information Strategy aims to enhance an information culture in which all members of the project understand the importance of information, in which the informational aspects of all project activities are fully taken into account, and which equips the project to work effectively in the external information environment.

An information strategy seeks to identify the objectives of the project and evaluate the most effective and efficient way to get the information. The best way to think of an Information Strategy is as a set of attitudes in which:

- any information that should be available for sharing is well defined and appropriately accessible (allowing for necessary safeguards);
- the quality of information is fit for its purpose (e.g. accuracy, currency, consistency, completeness);
- all project staff know, and exercise, their responsibilities towards information management;
- there is a mechanism by which priorities are clearly identified and then acted upon.

And finally, an information strategy describes the overall direction and general framework in which the project's information resources and processes should be managed, so that the

project would achieve its most important goals. An Information Strategy typically consists of the following:

- IM goals and objectives that are well aligned with the organization's mission and vision.
- IM principles that articulate desirable outcomes and form the foundation for developing information policies.
- One or more areas of strategic focus: this could be some critical information content; common information to be shared; some information-intensive process; or new information-based products or services.

As such the Information Strategy is concerned with the creation, management and dissemination of information as a project resource within the organization. It encompasses information in all formats and at all stages of the information lifecycle.

The Information Strategy has three main components:

- A set of principles defining the main elements of good information management practice, which act as a de facto standard for the management of information within the country office.
- Information Goals and Project Plan, outlining where we are now and where we would like to be at the end of the period covered by the current strategy.
- A strategy for implementing the tasks outlined in the above plan and for ensuring that the Information Strategy is regularly reviewed and updated via an information audit process

5.7 Information Politics

Information needs to live in an environment that encourages its use and sharing. This environment is similar to a federal structure, were a country office can define tight controls on the information flows and other areas were it is open and free to flow.

Types of information politics:

1. Technocratic utopianism: information management is based on a belief that technology is the ultimate solution.

2. Anarchy: the absence of an information management policy altogether where employees are left to “fend for themselves”
3. Feudalism: Individual projects manage their own information independently.
4. Monarchy: all information reporting structures are defined by the organization’s leaders, who may or may not share the information once they have it.
5. Federalism: information management based on consensus and negotiation.

For a project’s information management process to succeed it needs to live in a federalist environment where information managements is based on building trust which in turn fosters learning. With trust, beneficiaries will be more open to share valuable insights and donors will be more open to accept projects results and recommendations.

A project needs to asses the current environment; evaluate its advantages and disadvantages. Define what will be the ideal environment and create a plan to move and close the gap.

The Country Office must develop a project information culture, promoting the effective exploitation of information in order to support the programmatic interventions and provide a high level of service to our donors and project stakeholders. There must be commitment at a senior level to the successful implementation of the Information Strategy and its regular review and development. Awareness of the importance of information as an organizational resource should be promulgated to all levels of country office staff.

5.8 Information Culture

Effective information management is how people use information, not technology. For IM to be effective we need to consider the cultural characteristics of its environment.

Information Culture means the practices, behaviors and local customs that people have regarding the use of information. A project is influenced by the local culture and the organizational

culture, both of which determine the practices and behaviors for IM. A country office that rewards and encourages the use of information for decision making has better chances at IM than a CO where information is seen as a project by-product, another donor requirement, or a nuisance.

A project needs to assess the current practices and behaviors around information management and identify the areas that need improvement and support from upper management.

A culture that fosters IM has the following characteristics:

- Project Staff are aware of the importance of good quality information and take the necessary steps.
- Project Managers are using information for decision making.
- Staff uses information to enable changes and improve project deliverables, and make the time to learn from the experience.
- Staff shares information with other projects to share lessons and best practices.
- Staff knows where all project information is stored and know how to retrieve it.
- Information management is a constant effort and not driven by donor requirements, but by country office needs to improve impact and learn from the experiences.
- Information flows vertically and horizontally across the whole country office. It is not held at specific projects or units but open and advertised to all staff.

Information behavior refers to how project staff approach information, how they select, gather, store, classify, analyze, report and use information. Behaviors can include sharing, hoarding or ignoring it. Sharing information is not the same as reporting information, which is a more structured process. Sharing is an open and almost free, voluntary action that a project staff has to make information available to others.¹⁷

¹⁷ Information Ecology, Davenport, 1997

5.9 Information Governance

Governance is defined as the system and structure for defining information policy, providing leadership, and managing and coordinating the procedures and resources that ensures the quality of all project information. Governance also comprises the processes that determine how information management is exercised, how beneficiaries are given a voice, and how decisions are made on issues of project concern.

Information Governance Involves the culture of participatory governing, where communities are actively involved in decision-making processes.

To enable information management, projects and country offices need to develop new governance models with the power and influence to set and enforce standards and policies across the organization, Without this mandate Information Management is doomed to data gathering for data's sake.

If thoughtfully designed a transparent Information Management Governance enables projects to deal more effectively with less complexity. Results in clear lines of input and decision authority, leading to more informed, faster and better decisions. But it is not 'one size fits all', projects have different financial objectives, different strategic focus, and different donor and community governance drivers. Information Management Governance needs to take in account the realities of a project's environment and be flexible enough to adapt without losing sight of its main objective.

An information management governance framework or policy may range from a single document expressing essential elements to a linked set of principles, objectives, policies, standards and guidelines. In whatever form, it must clearly tell project staff and key project stakeholders why good information management is important and what must be done to ensure that it happens. It must communicate a vision centered on the responsible management and effective use of information and knowledge in support of project goals.

It should be based on fundamental information *principles*, such as:

1. Availability: Information and data must be created, acquired and maintained so as to document important activities and decision-making processes adequately;
2. Accessibility: Information should be accessible to, and shared with, those who need to access it and have a right to do so;
3. Stewardship: Projects should be accountable for ensuring the accuracy, authenticity, relevance and reliability of their information resources;
4. Creation and Retention: Project information should be created, acquired and retained only for valid program, legal, donor, accountability and organizational needs;
5. Privacy and Security: The security of information should be protected to ensure privacy, confidentiality and integrity, consistent with program, legal and donor requirements;
6. Life-Cycle Management: Information in all media and forms should be managed as a strategic organizational resource throughout its life-cycle (from creation or collection through storage, use, destruction or archival).

The Governance framework should address critical issues in the development and implementation of information management processes, including:

1. Governance: roles and responsibilities for governing information management processes and activities must be clearly assigned at appropriate levels.
2. Individual Responsibility: all project staff must understand their responsibility for maintaining good information management practices and have access to relevant standards, guidelines and training, especially with regard to electronic information; project managers, in particular, should ensure that an effective information management processes is in place.
3. Measurement: information management policies and processes must be periodically reviewed, evaluated and modified as needed.

4. Resources: projects must be adequately resourced to ensure information management effectiveness – this includes personnel, space, equipment, materials and training.

5.10 Information Architecture

An Information Architecture is a set of models, definitions, rules, and standards that give structure and order to a project's information so that information needs can be matched with information resources. Information architecture is also the structure and organization of information within a framework that describes the principles, standards and processes for managing information as a resource.

An Information Architecture defines:

- what types of information exist in the project
- where the information can be found
- who are the creators and owners of the information
- how the information is to be distributed and used.

An Information Architecture may contain several of the following:

- a model of main information entities and processes.
- a taxonomy or categorization scheme.
- standards, definitions and interpretations of terms.
- directories, inventories, resource maps and description frameworks.
- designs for developing information systems, products, services.¹⁸

An information architecture helps the project by first identifying all the possible sources for information that the project will need, it will locate information that already exists within and outside the organization. It helps the project by saving resources and time by locating information already available and thus avoiding creating the same information again, which reduces the time and cost of collecting, storing and processing project information.

¹⁸ Adapted from; Chun Wei Choo, faculty member of the Faculty of Information Studies at the University of Toronto.

5.10.1 Information Flowcharts

An information flowchart is a graphical representation of the information management process, it defines the steps required to collect, organize, store, analysis, report and use information. It identifies the owners of the different processes, their responsibilities and the dependencies. More detail is presented in chapter 5. An example of an information flowchart is presented below:

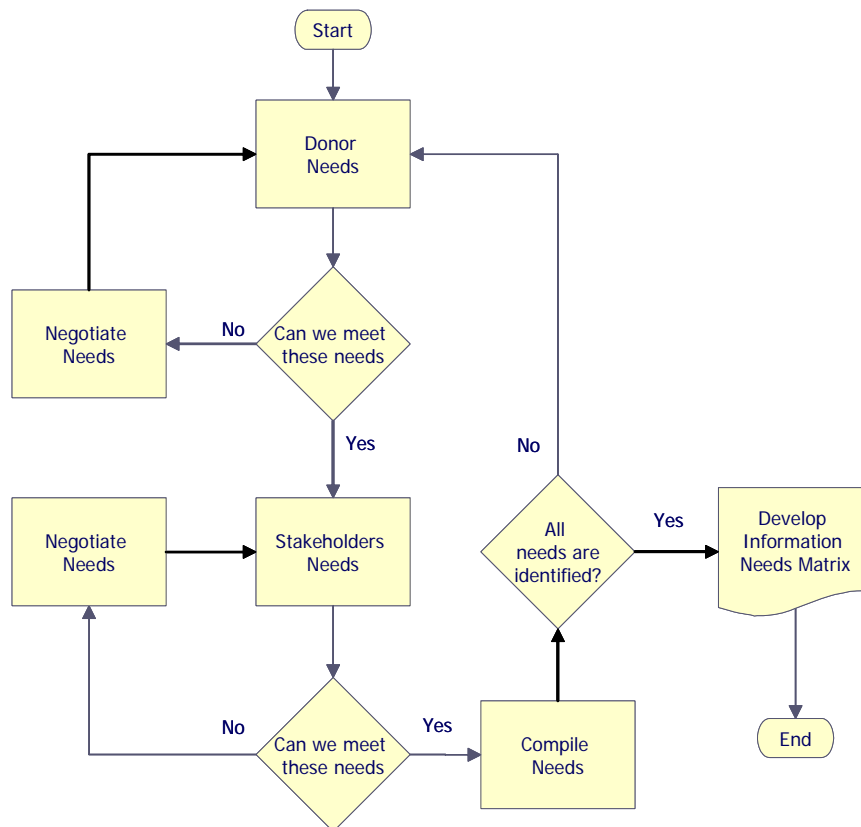

Figure 29 Information Flowchart for Defining Information Needs

5.10.2 Information Maps

In practical terms an information map defines the boundaries of information. It's a map that connects project information needs with project information sources. It defines what is important and what is not important. Gives a high level definition of where is the information, who has it, what it will take to have it and its relevance. It also maps the users of the information, who are they, when they need the information, how often. An information map contains **information about information**, including who

has responsibilities over information (ownership and stewardship), who uses information and how the information is or could be used.

An information map is intended to show what kinds of information are kept by the organization, where they are, how they are maintained, how access is provided. Information maps can be developed at several levels of detail. Logically the first pass should be a rough one intended to give an overall picture of the internal information resources and to suggest where further examination may be required.

Example of an information map on DME

Types of Information	DME Guidelines and best practices	DME Project Standards	Methodologies	Training materials	DME consultant information
Do we have it?	Yes	No	No	No	No
Who has it?	Project Manager	DME Coordinator at HQ	DME Coordinator at HQ		RMU and HQ
Where is it?	Project Library at Main office	CARE intranet at HQ	CARE intranet at HQ	CARE Academy Website	Consultant Databases
How we can get it?	Via email or pouch	Access intranet my-care.care.org	Access intranet my-care.care.org	email careacademy@care.org	Request RMU and HQ
Is it relevant to the project?	Yes	Yes	Yes	Yes	Yes
In what format?	Word and PDF	Word and PDF	Word and PDF	Web Training and CD-ROM	Excel worksheet

5.10.3 Project Organigraphs

An organigraph depicts the project processes, critical interactions, and relationships. In contrast to a project organigraph this way of mapping allows an understanding of the project, itself, not simply the names of its staff.

Another use behind this technique involves viewing the project as a set of processes rather than as a hierarchical stratum of power.

A project organigraph is a useful tool to visualize relationships and how the project interacts with them. This can be used as a knowledge map to identify and categorize the sources and users of project knowledge.

Example of a project Organigraph to chart the relationships a project develops:

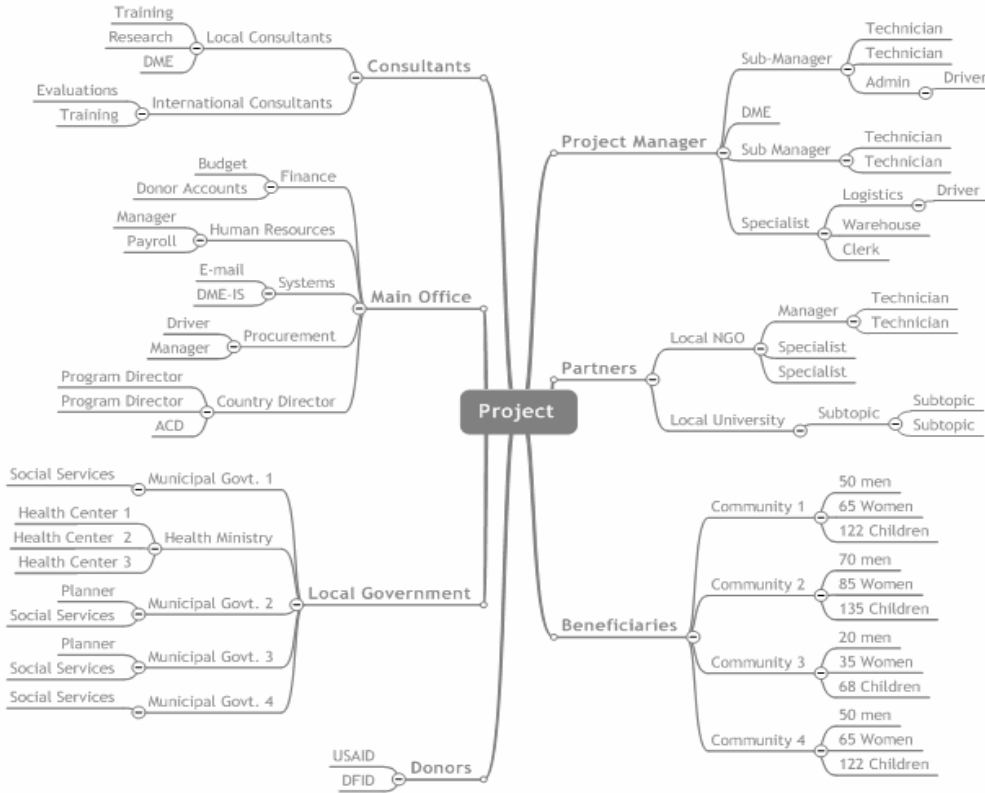
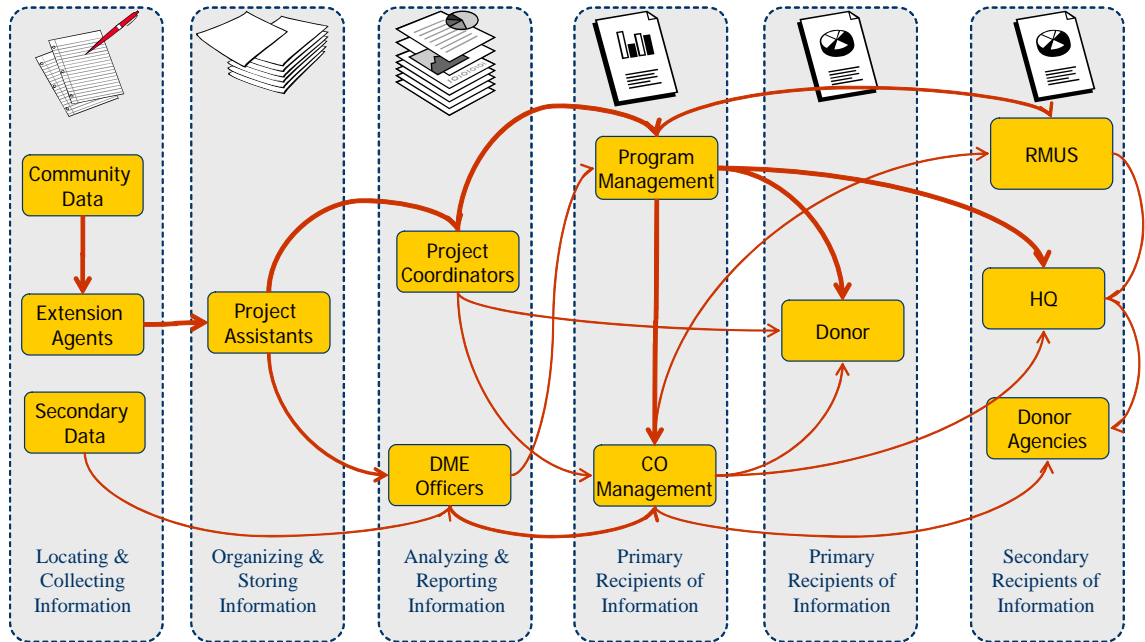

Figure 30 Project Relationships

5.10.4 Project Information Flows

Project information flows from the sources to the final users. This flow helps understand the different actors and owners of the information as it moves from origin to destination. It also helps understand where are the bottlenecks, the redundancies and shortfalls of information. The graphic below shows an example of an Information Flow Chart, the chart makes it is easy to visualize the flow and identify the areas for improvement. It is not uncommon for Project Manager, Program Mangers or Donors to be receiving information from different sources; information that could be redundant or contradictory. A project needs to determine its current information flow and redesign it for efficiency and accuracy.

■ From Source to Users



There are three major classes of information flows:

- Information access
- Information exchange
- Personal communication
- Work process
- Knowledge sharing

Information access

Information access is the most common form currently found in practice. Here project staff search for what they need to know to carry out their task. The most common ways to access information are:

- going to the library and finding some books or documents
- looking up catalogs,
- searching the Internet, Intranet
- searching some specialized database.

Usually in all these cases staff use some directory or index to find the needed information.

Information exchange

Information exchange occurs when people either send information directly to other people or display it for other people to access. There are many ways to exchange information. The most common are:

- send a message or document to a specific person or to a group of people;
- make a set of documents available for people to access;
- a newsgroup that collects information from a group of people and then mails them to a group;
- an electronic publication usually on the WWW advertising products or services;
- a bulletin board where people can post items of interest.

Personal communication

Personal communication usually involves an exchange of a number of utterances (or messages) with the same goal in mind.

Examples here include:

- explaining a situation through a set of questions and answers;
- brainstorming to get an idea about how to solve a problem;
- making a decision about a number of alternative actions;
- agreeing to a common course of action - such as the time of a meeting;
- identifying and evaluating an alternative.

Work process

Here information flows follow a determined procedure. Usually there is a procedure (which may or may not be formally defined) whose goal is to accomplish some outcome (such as fix a problem or prepare a report). The goal of the procedure is well-defined - for example purchase an item by first selecting a supplier, then making an order, then arranging delivery then sending an invoice, and finally processing the payment.

Knowledge sharing

This kind of work concerns people getting together from different areas and trying to combine and make sense of their ideas. The

combinations are usually made to construct some new ideas or service. Examples include:

- defining a consistent set of terms to be used in communication
- DME staff trying to see how to make sense of a donor's requirements,
- getting access to experts to help in some problem,
- interpreting each others work in relation to a common goal,
- forming a common goal from different perspectives - for example, administrative and programming staff trying to reconcile organizational and project goals.

It differs somewhat from personal communication. In personal communication the goal is often clear and the same terminology is often used. In knowledge sharing one is often trying to reconcile different terminologies and viewpoints between people coming from different perspectives

Mapping the way information flows is a process for analyzing how information is transferred from one point to another within a project or an organization and to understand the needs from each information user. It is also a method to visualize the immediate and wider context of the project, its outcome will produce a deeper understanding of the project and its links with its various stakeholders. The benefits of mapping the information flows are:

- An understanding of how information is used and by whom.
- Identifies the ultimate user of the various types of information as well the information that enters and passes through the project.
- Helps focus on the information with the highest potential benefits.

* * *



Chapter 6 Information Management

6

6. INFORMATION MANAGEMENT

“Information management is a process, not an event, and will only succeed if those involved understand the value of information and is committed to its effective use. Managing information is a means to an end, not an end in itself, and the real measure of success is how improved management increases the timeliness, appropriateness, and coordination of humanitarian assistance”¹⁹

Information management is the channeling of the information resources and information capabilities of the project in order to add and create value both for itself and for its stakeholders. Information management (IM) is the management of processes and systems that identify, acquire, create, organize, store, distribute, and use information.

A project needs to adopt a process view of information management, in this view; IM is a continuous cycle of eight closely related activities: identification of information needs, locating the information sources, acquisition and creation of information, organization and storage of information, analyzing and reporting information, information dissemination, information use, evaluating the information process.

The concept underlying Information Management is that just as a project purposefully and systematically manages its human resources and financial assets, it should do likewise for its information resources and processes. All the classic functions of managing an organizational activity apply to IM as well: defining goals, providing leadership, developing policies, allocating resources, training staff, evaluation and feedback.²⁰



Information Management describes the means by which a project efficiently manages its information resources, and through which it ensures that the value of that information is identified and exploited to the fullest extent.

¹⁹ Paul Currion, *Humanitarian Community Information Center*

²⁰ Chun Wei Choo, faculty member of the Faculty of Information Studies at the University of Toronto.

Information Management means the management of an eight step process of; defining, locating, selecting, collecting, analyzing, reporting, using, and evaluating information. This process is also known as the Information Life Cycle. A cycle that constantly feeds back to itself to improve the process on every cycle.

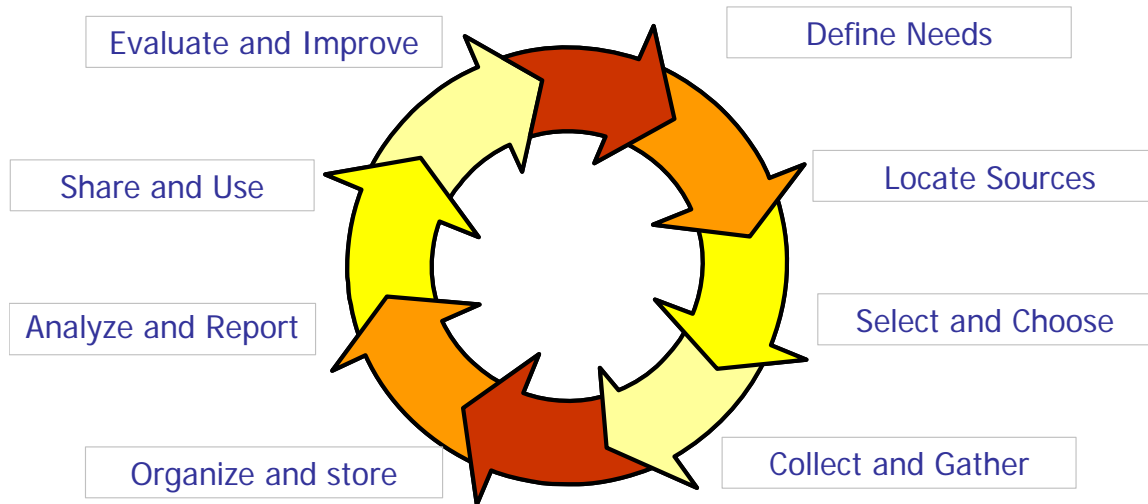
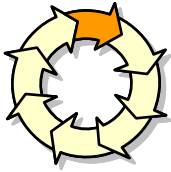

Figure 31 The Information Process Life Cycle

6.1 Defining Information Needs



Defining information needs is the first step in the information process. It is important to first ask what are the information requirements of all project stakeholders. This will give us an inventory of all the information that the project will manage during its life. Project stakeholder's information needs arise from problems the project is trying to address; a project should not limit to ask what you need to know but expand the question and add the why, when and how you need to information.

To develop an information management system, a project must first determine its information needs. A project's information needs are determined by the types of information it must maintain and the users who require access. A project's best interests are served with a thorough understanding of the needs of all internal users and as many external users of project information as possible (other agencies, the public, donors, local governments etc.) Such identification allows for customization of the plan based on specific requirements.

A project's information needs are dictated by:

- Legal and regulatory requirements imposed by local governments
- Requirements imposed by outside organizations
- Contractual requirements established by donor agencies
- Beneficiary (Public) demands for information
- Internal control operations

Each of these areas should be examined in detail to specify the project's information needs. In this examination, consideration should be given to both short-term and long-term needs and both regular on-going and temporary needs.

Project staff members who are responsible for reporting to outside agencies will be most familiar with the requirements of these outside agencies. For internal operations, each staff member's data requirements are dictated by the staff member's responsibilities. The person most familiar with the job will be able to specify the information needed to do the job efficiently and accurately. The increasing reliance on site-based decision making generally means that more information must be made available to more people. Including personnel from all areas of a pro-

ject in the development of the information management plan increases the chances of the plan's success.

After this information is gathered, it should be analyzed and compared to the project's current efforts. In particular, a project should look for duplication of effort (for example, multiple staff members citing responsibility for reporting identical information), requested information needs that do not match a staff member's level of authority and obvious omissions in the project's information needs.

6.1.1 Who needs the information?

Our first step is to identify all the project stakeholders who need information. Our first stakeholder is the project donor (or donors). Most of the donor's requirements are already part of the contract or donor agreements, they may include specific information that the project is responsible to collect and present to the donor at specific intervals or project milestones. Some may even be required before any disbursement are made to the project and may be a necessary condition to accept the project's final outputs.

Other important project stakeholders include local governments who need the data to feed their own information systems, for example health information. These could be also regulatory requirements that the project is mandated by local law to collect and report to local or national government agencies.

Country Office Management. Main focus is on project progress, they need to know about project schedules, deliverables, expected outputs, evaluation reviews, changes and deviations in the plans, potential risks and delays to the project.

Communities need information to monitor progress and evaluate how they are doing; the format of how to present this information needs to be carefully defined and takes in consideration literacy levels, cultural, religious and political environment of the community. Communities need to be involved earlier in the project information management planning stage as they will be the main source of project information.

CARE Headquarters and CARE International. Their needs for information is less critical and required on a yearly basis, these

may include Annual Project Information and reports on key organizational indicators.

Other users of information may include staff from other similar projects, project partners, and other development organization with whom we share information.

Finally, an important user of information is the project itself, project staff and project management needs to define what information they need to bring the project to a successful completion. The information may include technical manuals, methodologies, processes, training documents, consultant evaluations, best practices, subject matter experts, etc.

Project staff need to interview project stakeholders and try to obtain a good definition of their information needs, its not enough to ask “what you need” but to drill down the requirements into manageable sets that enable a good identification of the data and information the project needs to gather, analyze and report back to the stakeholders.

6.1.2 What Type of information is needed?

The type of information defines its use and purpose. A project needs to classify the information needed

- Quantitative and qualitative information
- Project progress reports
- Project evaluations
- Baselines and Statistical information
- Lesson Learned and Best practices
- Technical manuals and methodologies

The project needs to classify the information types into its basic data components and organize it according to common characteristics. For example a project identifies that all the project information needs from its stakeholders can be obtained from the following data components.

Information Types	Source	Who needs it?	Format
Project progress Reports	Project Schedule	Donor Program Manager	Excel spreadsheet with chart.
Annual Project Information	Project DME-IS	CARE HQ	GYST Format

Community Base-line	Community members Family Surveys	Project age-ment Donor	Man-	Survey Forms
Community crop yields	Community farmers	Project Donor Government		Table Charts Report

6.1.2.1 Baseline Data

Baseline data describes the situation before the project or intervention happens. Therefore, baseline information must be collected before the start of a project. It is used during the project to indicate progress towards the goal and objectives and after the project to measure the amount of change. The information collected in the needs assessment can be part of the baseline data.

It is important that the information collected and used for baseline data actually describes the situation that the project goal and objectives are addressing. If the information is not relevant, you will not be able to evaluate the goal and objectives properly.

6.1.2.2 Information for a process evaluation

Data used to measure the project is collected as the project proceeds. Data collection needs to be coordinated with the actioning of the process. The process of a project are the methods that the project is using to achieve its objectives. The process must be evaluated before the objectives can be evaluated. If the process are not going well then there is little chance of reaching the objectives. Therefore, there is little point evaluating whether the objectives have been reached.

6.1.2.3 Information for an output evaluation

In order to see whether the objectives have been achieved, it is necessary to collect data which relates to the objectives:

- o immediately before the corresponding activities are put into action
- o then after the activities are completed

Compare the two sets of information. Is there a difference? What is the difference? Is it what was being aimed for? Has the objective been achieved?

6.1.2.4 Information for an impact evaluation

Collecting data to measure the final goal is done at the end of the project. It is then compared with the baseline data that described the situation just before the project started. The goal is reached by achieving the project objectives. If the impact evaluation shows that the objectives have not been met, then there is little point measuring to see if the impact goal has been met.

The amount of time required for monitoring change and before final evaluation of the goal will vary, depending on what the goal is and how quickly change can be expected. This time factor is something the project team will have to think about and discuss when planning the evaluation.

6.1.3 Why they need the information?

A Project needs to have accurate and timely information to assess the value of what it is doing. The following list shows some of the key reasons why information is needed by the project: ²¹

- Achievement – what has been achieved? How do we know that the project caused the results?
- Assessing progress – are the objectives being met? Is the project doing what the plans said it would do?
- Monitoring – is the project well-managed?
- Identifying strengths and weaknesses – where does the project need improvement and how can it be done? Are the original objectives still appropriate?
- Checking effectiveness – what difference has the project made? Can the impact be improved?
- Cost-effectiveness – were the costs reasonable?
- Sharing experiences – can we help to prevent similar mistakes or to encourage positive approaches?

Adapted from: Feuerstein, 1986

6.1.4 When they need the information?

Timing is an important element in allocating project resources to produce the required information. Assign to each information

²¹ CARE DME Guidelines

user the type and frequency of the information needed, and track this need against the project calendar. Users are dependent on receiving the information on time to make decisions, and the project needs to plan for the time it will take to gather, process and report on the information. Match each information requirement with its corresponding schedule:

- Weekly
- Monthly
- Four times a year
- Two times a year
- Once a year
- Before disbursements
- At project evaluations

Example of a project calendar and its information needs milestones.

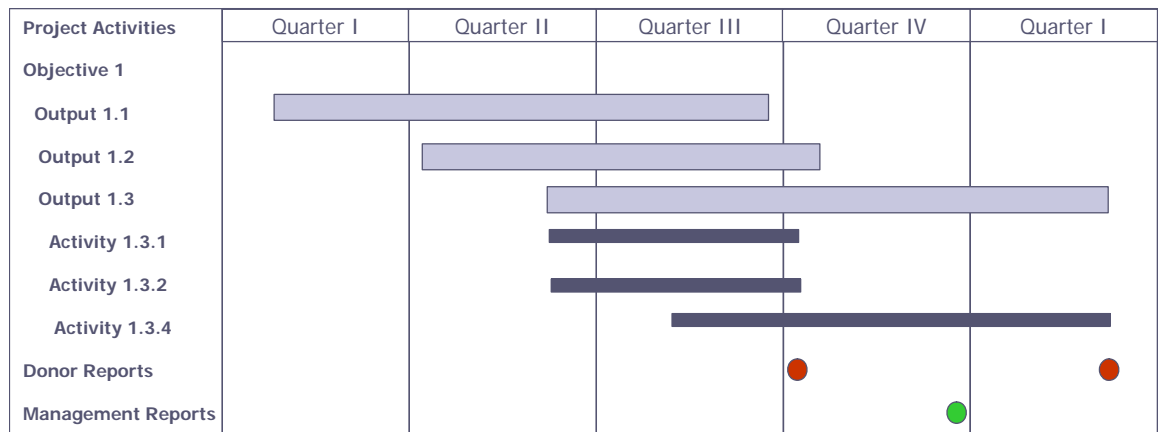

6.1.5 How they want the information?

Each user needs to have the information available on a specific format. The format may vary from forms to reports, from pictures to video, from simple charts to comprehensive analysis. A project information system needs to be able to deliver information in the formats required by the key project sponsors.

A project needs to assess the detail of the information needed, as this may have a large impact on the use of projects resources. Make a clear distinction between “must have” information and “nice to have” information. The first is a requirement, the second a luxury. A project needs to concentrate on the in-

formation that will provide the best opportunities to measure its impact, everything else is just a luxury that the project cannot afford to have.

Each hour spent in managing “nice to have” information is an hour the project loses to concentrate on the “must have” information.

Determine the type of format the information is required, these may include:

- Forms (donor or government forms)
- Data reports (includes charts and graphs)
- Database sets (specify database versions, MS access, SQL, etc)
- Document on electronic format (specify word processing versions, size limitations)
- Document hard copies (number of copies)
- Pictures in electronic format (specify format and size)
- Printed pictures (specify size and color or black & white)
- Voice recordings (analog, digital)
- Video Recordings (specify format VHS, 8mm, DVD).

6.1.6 Matrix to identify information needs

Who	What	Why	When	How
Donor	Progress reports	Re- Monitor progress and	Every three months	Donor format
Government				
Project	Financial reports	Re- Monitor expenditures vs. progress	Every month	Scala Reports from Finance
Communities				
Partners				
Management				
HQ-CI	Annual Project Information	Track global indicators	Every year around August	GYST
Others				

Table 5.1 Defining Information Needs

6.2 Locating Information Sources

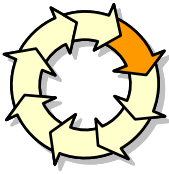

A major problem facing projects is locating information sources corresponding to their needs and equally important, information providers often do not find appropriate venues for presenting their information, which then remains inaccessible to others. Locating information sources and finding information within those sources requires a careful planning and analysis from project staff. Each piece of information the project needs to be localized and an inventory created that will identify where is the information, who owns or controls the information, and what the project needs in order to get the information. Locating information requires a strategy that will facilitate the identification of information sources that are valid and reliable.

The information management system must identify an appropriate source for each type of information required. A project acquires information from both internal and external sources. For all internal sources, the plan should describe how the information will be collected and stored.

If there are multiple sources for a particular type of information, then sources must be judged based on efficiency, accuracy and how close the source is to the origination of the data. A direct flow of information is generally the most efficient and the most accurate. The project should determine the most efficient source and modify its data collection procedures if a proposed source is more efficient than the existing source. For example, if one program director currently receives project information from another program director who receives the information from the project, it may be more efficient for the project to provide such information directly to all program directors. This direct flow ensures that all directors receive the same information in the same time frame and reduces the potential for information to be miscommunicated.

Generally, information derived from an original source is more reliable than secondary information. As an example, a project's DME coordinator should provide DME training to all appropriate staff in the project. However, every staff member who is responsible for some aspect of DME reporting should have a copy of the most current DME Guidelines and other relevant references, including the DME Project Design Handbook. Staff members need

access to the original source document, not just the information shared by the DME coordinator.

6.2.1 Where is the information?

Information is everywhere, the difficulty resides in identifying where the best information is located. Using the information requirements matrix, the project needs to connect its needs with the sources and then properly classify which are valid, reliable and dependable. Information sources can exist in different levels, what is important to remember is that the project should not try to collect all the information from direct sources, collecting raw data is expensive and time consuming, in many cases the information is already available from other sources, with some research and creativity the project team can find alternative sources of information less expensive and more convenient.

Basic sources for information available to a project:

Organization Sources

Internal information, captured by other projects or other staff in other country offices. External information located at other country offices, headquarters and CI.

Country Sources

Government Information. Sources of information that have the required level reliability and quality, may include country statistics collected by government agencies and local municipalities, evaluations on similar projects, experiences on similar methodologies, etc.

Community Sources

Information on the community includes beneficiary needs and perceptions, surveys, adoption rates, feedback, etc.

Other Sources

Other non governmental agencies collect country information that the project may consider to be useful for the project's purpose. Other sources can also include; consultants, partners and other local organizations, the internet (if available), libraries, universities and research centers.

A project needs to map its information sources and classify them according to how close and accessible and reliable the information is to the projects and how expensive or difficult to obtain. The graphic below shows an example of an information source map.

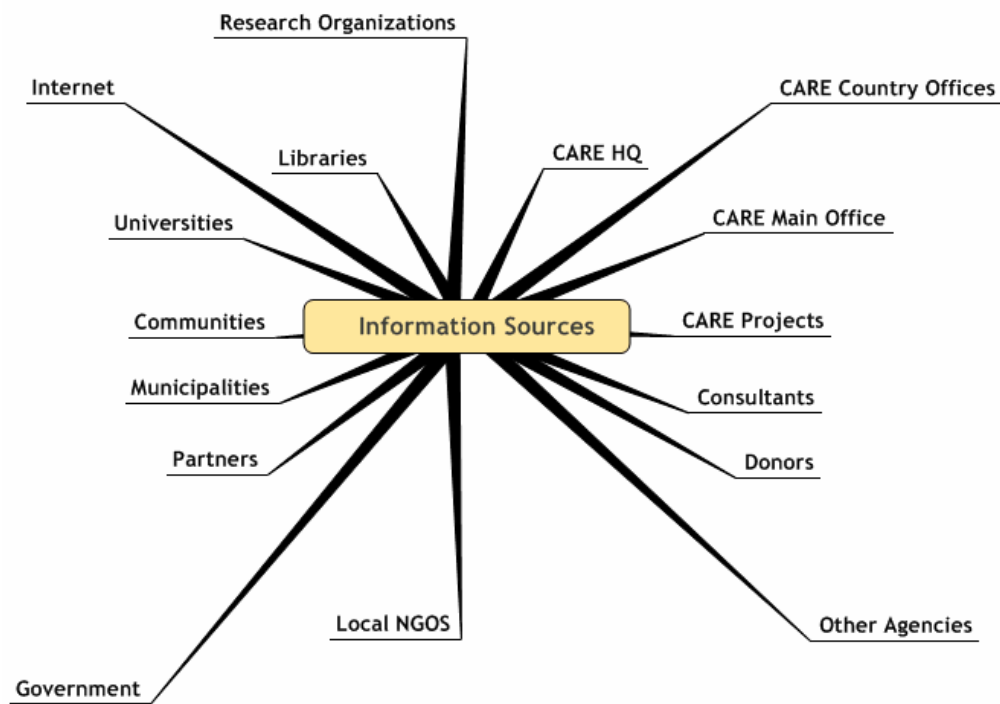

Figure 32 Map of Project Information Sources

A map can also be used to define information sources and the level of relevance the information has to a country office needs. The map to the left shows a country office surrounded by different layers of information sources, each level defines a degree of relevance, the closer the layer the more relevant it is to the CO. This can help in determining the strategies a CO needs to collect information from these sources.

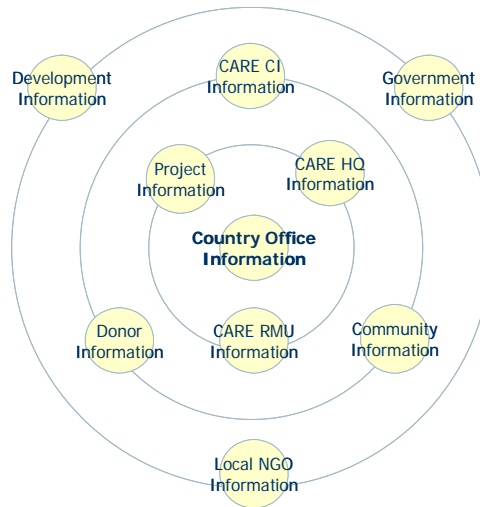

Figure 33 Information resources Map

6.2.2 Who owns the information?

Information is power, and the way to exercise this power is by controlling it. Many sources of information may be located in places where there is too much control on it. Ideally information should be made available to all who need it but that is not always the case. A project needs to investigate who owns the information and identify the barriers that may be in place to get to it. In many cases the information could be in a different language, protected by copyright laws or inaccessible to the general public. In other cases the information may be embedded in people's experiences, practices and behaviors.

6.2.3 How do we to get the information?

Once the project has located and identified the "owners" of the information it needs to find out what it needs to do to have access to it.

This needs to be balanced with the cost and effort needed to get the information. The project will evaluate the best and more cost effective method to get the information.

Ways to get information are:

- Collection from primary sources, this means that the project by the means of surveys and other tools collect the informa-

tion directly from the source (beneficiaries). Its more time consuming and expensive due to the logistics but assures we get the information we need and in the quality we need.

- Collection from secondary sources, this means the project gets the information from other organizations or agencies who have collected it. The information may not be complete or meet all our needs, its less expensive but there may be issues with quality, bias and other factors that limit its usefulness to the project. This kind of data can be used to support our own findings, make a quick assessment before investing in a direct collection of data, and fill any gaps in our collected information.

6.2.4 Table to classify information sources

TYPE	CARE	GOV	NGO	COMMUNITY	OTHER
Community Health Statistics	NA	Ministry of Health statistics	Partner NGOs databases	NA	NA
Market Prices	NA	Published market prices, government publications.	NA	Survey and interviews to farmers.	Sampling of prices on local markets

By organizing the information sources with the type of information a project can identify the gaps and redundancies of the information required by the project. The table above can also be used to classify information sources by its relevance, usefulness, accuracy, credibility and significance.

6.3 Selecting Information needed to collect

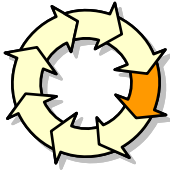

How to select information relevant to the project and ensure such information is accurate and relevant is a critical step in determining how the project will manage its information. Unfortunately projects are overwhelmed by too much information; too many things to read, too much to absorb. It's hard to slow the tide of information, because new events, ideas and discoveries are always turning up. In these circumstances a project is always at risk of being overloaded with information and some techniques for selecting are needed to prioritize sources specifically a project needs to know if its information sources are: relevant, significant, useful, accurate and credible.

6.3.1 Is the information relevant to our needs?

Although it would nice to be able to have all the information possible on every area, for a project's life span that may not be possible nor desirable. A project needs to evaluate its information sources and choose which ones are relevant for its needs.

Each source needs to be evaluated and analyzed to discover if the information it provides will be able to answer the questions the project needs to answer, questions driven by the needs of project stakeholders to monitor progress and make decisions to improve the effectiveness of the projects interventions.

Keep in mind that relevance means information that will support the project need for decision making. Information that is not relevant is not needed and the project should not spent time and effort in trying to collect it. Classify each information source with a degree of relevance from high to low.

6.3.2 Is the information significant?

All information sources may be relevant to a project needs, which at the beginning of the project can be quite large. Another filter the project could use is to test if the information is significant, that is if the information will have an impact on the project. For example, information on water use habits and information on rain downfall may be both relevant to a water project, but if the main project goal is to reduce cases of diarrhea in infants, then

the information that has the most significance to the project is the one about consumption habits. Significance can help decide what information source should be given more attention and analysis.

6.3.3 Is the information useful?

Not all the sources, in the vast information inventory, will be appropriate for the question the project needs to answer. See if the information can be used in its present form, or if it needs additional analysis or confirmation from other sources. If the information collected doesn't lead to a decision then it is information not useful for the project. Think of information as an expensive resource that the project will purchase, its value resides not in collecting and storing it (no, it is not an inventory item) but in its use, only when we use it we are receiving full value. Another indicator to test an information usefulness is to see if the information can be obtained on time and if the information is current.

6.3.4 Is the information accurate?

Determine whether the information is fact, opinion, or propaganda. Factual statements should be well documented and/or footnoted so they can be verified for accuracy. Check for bias by looking at the original source. Some sources attempt to influence public opinion by advocating or presenting a specific point of view. Look at the language of the source to see if it is objective and impartial, or emotionally charged. Ask yourself the following:

- How is the information presented?
- If the information is presented as fact, or as an opinion?
- Is there evidence of bias?
- Is it correct and verifiable?

6.3.5 Is the information credible?

While analyzing the sources of information and trying to define if each source is useful, take in consideration and evaluate if the information is not affected by any bias, prejudice or inconsistencies. A project may spend resources to collect information that its use may lead to wrong conclusions or incorrect actions.

If the information comes from secondary sources take the necessary time to investigate if the source is credible and reliable,

that is, if the information provided has been of good quality consistently, that it can be audited and that other projects or organization have been using it in the past. Information sources from government agencies or other organizations can have biases that respond to political, religious or cultural motives, this information needs to be taken with caution and not used as the main source but as an alternative source. The credibility of an information source can have an impact on the project final evaluation and on the credibility of the project results.

6.3.6 Is the information difficult or expensive to obtain.

When selecting information evaluate the cost of collecting the information. A project may decide that it is for its best interest to collect directly all the information, but the cost of this enterprise may outweigh the benefits.

6.3.7 How much information we need?

How often we forget to define the information we need and we end up with collecting large volumes of information that at the end of the project were never used.

A project needs to analyze all its information needs and determine which ones will help the project. DME-IS cannot be an effective tool for the project if the project takes an attitude of collecting data for data's sake.

The project needs to identify the type of information that can provide the team with a "snapshot" of all the critical activities to give all stakeholders a good idea of the project progress. There is no need to treat DME-IS as a continuous detailed record of all data and activities, just like a financial system would. For example there is no need to conduct surveys of all beneficiaries when a simple random sample can provide the project with data that has a good level of confidence as a much larger data set would. By carefully selecting the information we need to identify trends, problems or opportunities we then can determine corrective actions without adding work load to an already taxed project staff.

For each category of information and for each piece of information that needs to be collected by the project, we need to ask a basic question; How would this information, once collected, can help the project meet its objective?. In other words, where is the

value added of collecting the information?. A simple test is to see if any information collected was not used by the project (to make decisions to improve its performance) then the information is not needed.



The cost, effort and time spent in collecting information needs to be balanced against the relevance and importance of the information to help the project meet its goals.

The project can't afford to waste time and money to collect data that will not be used, or analyze information that does not help the project or its evaluation. By reducing the effort of collecting ancillary information we are freeing up valuable resources to the project that can be better utilized in reviewing and improving the project. Keep in mind that the goal of our projects is to reduce poverty, and thus collecting information should be kept to a minimum to focus on the delivery of outputs that will create the expected benefits.

Creating information overload is quite easy and that can have negative impact on the project as it tries to spend more time in managing databases and records to the point that it loses sight of the project goals. There is no point in generating reports that take six months to produce when they were needed to support a decision four months ago.

A final advise is to keep the project staff from collecting data just because it will be "nice to know" The objective of DME-IS is to keep things simple enough for the information to be significant to the goals of the project.

6.4 Collecting and gathering the information

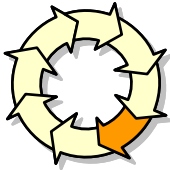

A project should ensure that duplication of effort does not occur in the collection of data. As much as possible, a project should strive to have a consistent source for each type of information. If a project maintains multiple data bases for surveys (records maintained by the project office and separate records maintained by the program staff), the possibility of problems relating to accuracy and consistency of project reporting will increase. The project's information management system should address the following:

- How will data be collected?
- Who is responsible for the data collection?
- When will data be collected?
- In what format data will be collected

The method for collection of information depends on the type of data and how it will be utilized. It may be done verbally, with paper documents or with magnetic media. The project manager should assign collection responsibilities to specific staff members to ensure that expectations are clearly understood and that duplication of effort is reduced.

The system should incorporate reporting deadlines when appropriate and establish time frames for all collection tasks. It should clarify which time frames include due dates that are fixed and those that are simply target dates. For collection activities that require data to be collected or reported in specific formats, the process should either specify the format or refer to the source documents that provide the information.

A project may use a variety of documents to address these issues; timelines, charts, checklists and information flow diagrams are a few examples of documents that may be useful. Some of these documents require frequent or periodic updating.

6.4.1 Defining the Methods.

One of the difficult decision a project DME-IS needs to make is to decide the method for collecting data, the projects needs to balance the needs for data and the cost or funds available to accomplish this activity. A method is defined as an established and

systematic way of carrying out a particular task, for our purposes the method we choose to collect information also needs to be established and systematic and has to be one that meets the project needs.

The project needs to take in consideration that evaluations for the project are measuring change. The kind of data the project will collect and the information it will look for will depend on what the project is trying to do or change; therefore, it must match the project goal and objectives.

There are two basic considerations the project will need to take in account when deciding how to collect information;

- Quantitative versus Qualitative
- Participatory or Non-participatory (Observatory)

6.4.1.1 Quantitative methods

Qualitative methods measure the status or change of a specific indicator, for example the number of roads improved, the changes in crop yields, the method provides with numerical results.

6.4.1.2 Qualitative methods

Qualitative methods are used to gather information from beneficiaries or partners by asking them to explain what they have observed, believe or feel, the method provides with textual descriptions. Methods may include techniques to capture audio or video as another method to capture people's expressions to measure change over time.

	Quantitative Methods	Qualitative Methods
Purpose	Used for measuring extent or prevalence (i.e. 80% of young people have heard HIV/AIDS)	Used to understanding context, gain perspectives of people
Scope and scale	Used in surveys, large sample	Used for more in-depth analysis of case studies
Type of questions	Closed	Open-ended
Type of information	More extensive, number based	Richer and more in depth, in the form of words
Time to collect data	Less time for each interview	More time for each interview
Time for analysis	Less time to aggregate and process data	More time to interpret and summarize information
Cost-effectiveness	Collection of data is more expensive (because usually requires larger sample survey)	Cost is higher in analysis
Interview participation	Medium (more extractive)	High (more participatory)
Flexibility of protocol	Strict protocol	High flexibility
Interviewer's skills and experience	Basic skills needed	Significant experience
Statistical basis	Valid and statistically reliable	Credible

From MER Guidelines

6.4.1.3 Participatory methods

Participatory methods of data collection can bring new insights into peoples' needs for project planning and implementation, but are no less demanding on skills than questionnaire surveys. They are time-consuming and require substantial talent in communication and negotiation between planners and participants.

A primary consideration for the collector of information is privacy. Many communities have already completed extensive surveys, either with CARE or other organization with no issues arising and with no one objecting to giving this information to the community. People in the communities should know that the information asked of them is voluntary, communities are comfortable providing their general information but they don't want anyone to solicit personal or private information. It must be clear at the outset that this isn't the intent of the survey.

6.4.1.4 Non-Participatory methods

These may include observations and use of secondary data from other sources that provide enough information to the project. Individual interviews and surveys are also part of this method.

Pros and cons of collecting data from groups or individuals²²

	Advantages	Disadvantages
Individual	<ul style="list-style-type: none"> Manage the discussion more easily Can get detailed information Generate data that can be structured in a way that makes statistical analysis possible 	<ul style="list-style-type: none"> Consumes more time if data is needed from many individuals Cannot be used to generate consensus Does not allow cost-effective feedback
Group	<ul style="list-style-type: none"> Generate new learning in some participants as information is shared Can allow for marginal voices to be heard Can show where divergence and convergence of opinions lie 	<ul style="list-style-type: none"> Can cause problems in terms of data validity and group dynamics may influence individuals Cannot deal with sensitive information Requires a facilitator able to deal with group dynamics Requires careful thought about group composition

6.4.2 Defining the Techniques.

As important it is to define the method the project also needs to define the techniques. The following chart provide with a general overview of the most common techniques to collect information

²² Managing for Impact in Rural Development. A Guide for Project M&E, IFAD 2002

Techniques	Overall Purpose	Advantages	Challenges
Questionnaires, Surveys, and Checklists	When need to quickly and or easily get lots of information from people in a non threatening way	Can complete anonymously inexpensive to administer easy to compare and analyze administer to many people can get lots of data many sample questionnaires already exist	Might not get careful feedback wording can bias client's responses are impersonal in surveys, may need sampling expert doesn't get full story
Interviews	When want to fully understand someone's impressions or experiences or learn more about their answers to questionnaires	Get full range and depth of information develops relationship with client can be flexible with client	Can take much time can be hard to analyze and compare can be costly interviewer can bias client's responses
Documentation Review	When want impression of how program operates without interrupting the program; is from review of applications, finances, memos, minutes, etc	Get comprehensive and historical information doesn't interrupt program or client's routine in program information already exists few biases about information	Often takes much time info may be incomplete need to be quite clear about what looking for not flexible means to get data; data restricted to what already exists
Observation	To gather accurate information about how a program actually operates, particularly about processes	View operations of a programs they are actually occurring can adapt to events as they occur	Can be difficult to interpret seen behaviors can be complex to categorize observations can influence behaviors of program participants can be expensive
Focus Groups	Explore a topic in depth through group discussion, e.g., about reactions to an experience or suggestion, understanding common complaints, etc.; useful in evaluation and marketing	Quickly and reliably get common impressions can be efficient way to get much range and depth of information in short time can convey key information about programs.	Can be hard to analyze responses need good facilitator for safety and closure - difficult to schedule 6 or 8 people together
Case Studies	To fully understand or depict client's experiences in a program, and conduct comprehensive examination through cross comparison of cases	Fully depicts client's experience in program input, process and results powerful means to portray program to outsiders	Usually quite time consuming to collect, organize and describe represents depth of information, rather than breadth

6.4.3 Defining responsibilities.

Who is responsible for collecting the information? In a sense all project staff are in one way or another involved in the process of collecting information. Whether it is quantitative (surveys) or qualitative (interviews) information, project staff need to take a systematic approach to define responsibilities on who collects information. By defining responsibilities the project avoids two basic problems: information that ends up collected twice or information that is not collected at all.

Define responsibilities by developing a matrix that identifies the staff responsible for information gathering and the type of information they are responsible for.

The staff selected as responsible for collecting information need to be well informed as to the requirements, sources, uses and frequency the information needs to be collected.

6.4.4 Frequency of collection.

How often the project needs to collect the information? This is mandated by the type of information and by the indicators chosen to monitor project progress. Frequency of collecting information needs to be weighted by the projects needs for information by the needs of the final users of information (donors, management, government) and by the sources of information and their availability to provide it on a timely manner. For example it would be ideal if a project could collect information as frequent as it needs it but it is dependent in the availability of the beneficiaries to provide the information. The projects needs to be careful not to burden beneficiaries with too frequent surveys.

6.4.5 Defining the format.

What format is needed to collect, organize and report the information? This is very dependent on the uses that the information will be give. Donors in some cases define the format by which information needs to be collected, in other cases would be local governments like health ministries that require the project to use specific formats to collect health information.

There are different formats for collecting information:

- Paper surveys filed by hand

- Surveys filled electronically by means of PDAs (personal digital assistants).
- Downloading tables and databases from the internet
- Pictures from films (slide and print)
- Digital pictures, in JPEG, GIF, RAW format
- Sound in digital and analog formats (audio tapes, WAV, MP3)
- Video in both digital for CD or DVD
- Video for VHS or 8mm formats

The projects needs to be consistent in the format it collects information, changing formats in mid way can result in users not being able to see, hear or read the information.

6.4.6 Information gathering matrix.

The following matrix/table is an useful tool to help the project define the responsibilities, frequency and format of the information.

Information Type	Who will collect	When will be collected	Format for collection
Baseline			
Progress Surveys			
Questionnaires to measure changes			
Final Evaluation			

6.4.7 Information Collection Review

After identifying the information that needs to be collected and when designing the forms to collect the information the project will need to validate the relevance of the information to the objectives of the project.

It is quite easy to come up with a list of questions for a survey, the difficult part when the data arrives and the projects has to make sense of all this data and convert it into information useful for the project. Each survey or information requirements should be analyzed to see whether or not the data collected has a valid reason to be collected an analyzed and how once collected it will support the project decision and monitoring processes.

For each information requirements ask questions like: why do we need this information, how it will help us in making a decision, how difficult is to get this information, is it relevant to the project objectives, are there other sources for this information. The

table below can help in determining the validity and relevance of each question on a survey.

Survey Question	Relevance	Purpose	Accuracy
	Why we need this information, how it relates to the objectives and goals	How will this question help the project. To what purpose will this information be used	How accurate is the information we need? What are the levels of accuracy we can accept?
Question 1			
Question 2			
Question 3			
Question 4			

6.5 Organizing and storing Information

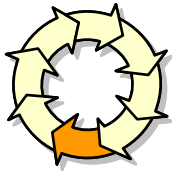

Project Information must be organized in order to permit analysis, synthesis, understanding, and communication. Organizing project information is important because it allows to: manage and retain the information more efficiently, communicate the information more effectively, recognize the need for further information and discard unneeded information, recognize trends, clusters, and other patterns in the information gathered, synthesize disparate pieces of information into new knowledge.

A project needs to organize its information into logical easily understood categories to increase its access and use. By organizing information a project is able to:

- enforce standards for the representation of information;
- relate different pieces of information to one another in meaningful ways;
- protect information from destruction; and
- make information available for people to use

The organization, storage, and retrieval of information is a critical component of information management. The project needs to be able to find the specific information that best answer a query, and to collate information that describes the current state and recent history of the project. Well integrated archival policies and records management systems will enable the project to create and preserve its memory and learn from its experiences.

The potentially severe consequences of the loss or inability to find vital documents are a driver to seek more versatile information storage and retrieval systems that can capture, store and retrieve structured and other unstructured data. Instead of efficiency, the overall system requirement now becomes flexibility. the DME-IS information organization system should capture hard and soft information, qualitative as well as quantitative data, support multiple user views of the data, link together items that are functionally or logically related, and permit users to harvest the knowledge that is buried in these resources. Because the same information can be relevant to a range of different problem situations, it becomes necessary to represent and index the unstructured information by several methods.

Organizing and storing information may be facilitated with the application of information technology. Projects with significant

volumes of information could need to reorganize and unify data from several sources, and provide friendly but powerful analysis tools that allow decision makers to search the data for strategic insight, so that, for example, they can discover patterns and opportunities buried in the volumes of beneficiary data.

6.5.1 Organizing information.

One way to organize the information you have gathered is to group materials by similar concepts or content. Another way of organizing information is to create an outline. An outline arranges materials hierarchically and sequentially by identifying main topics, subtopics, and details under the subtopics. Outlines allow you to group materials by similar concepts or content and put them into a logical order. Organizing information makes it easy for project staff to find it. Rather than answering to a query by providing the user with all the data collected by the project, we need to be able structure and synthesize the information so that its retrieval can be more specific to the needs.



"We still have this library metaphor of 'Let me give you back a bunch of books that might help you,' ... rather than 'Let me go through the books for you and figure out what you're looking for'" Jim Rugh DME Coordinator Care

6.5.2 Storing the Information

Storing the information is a means by which it can be recalled later by project stakeholders. There are five basic considerations a project needs to take in account when deciding how to store information.

- The format of the information, in the same manner as when we looked at the formats to collect information, the storage of information also needs to consider the format and means by which it will be stored, whether in a physical or digital format
- The security of information, security of information is a key consideration. The project needs to identify what information is secure and what information is public. Who has access to the information and who is responsible for safekeeping the information
- The availability of the information, information needs to be available to its intended users once it has been properly collected and organized. With the adequate measures for secu-

rity, information should be made available upon request by the authorized personnel.

- The legal requirement to store the information. Governments and donors have legal requirements for the storage of information, they may include privacy clauses and clauses that determine the length the information needs to be stored by the project for auditing purposes.
- The organizational requirement to store the information. This requirements comes from the need to have the knowledge and experience of the project stored for future reference by other projects

The project will need to setup a library or file storage system that is well classified to easy retrieval of the information, the method to classify the information should be made available to all project staff and key stakeholders. In the case of information in digital or electronic format, the project should follow the same recommendations for classification and access to the information. This can be by using shared folders on a computer that project staff can have access or by storing the information on a mutually accessible network server or intranet.

6.5.3 Securing the Information

All project information needs to be classified as either private or public. Public information is available to any person and its contents do not compromise the rights of any beneficiary or person mentioned on the information, nor the security of the project and the organization. There may be cases when the information is critical and its contents are meant only to few key staff, in that case the project needs to take the necessary measure to ensure that the information is secure, in its storage and in its manipulation when its is distributed to its intended users. In the case of digital information the project will need to put measures in place to encrypt the document or database to keep outsiders or non authorized personnel from opening and reading it. In the case of paper documents a file cabinet with a lock or in a secure room will need to be considered as appropriate methods.

Projects work in areas or environments that are not secure due to local conflicts, the information that the projects manages needs to be secure from reaching non-authorized personnel as it travels in personal briefcases or via email. All computers and networks of the project will also need to be evaluated for unauthorized intrusion and attacks.

6.5.4 Project Document management

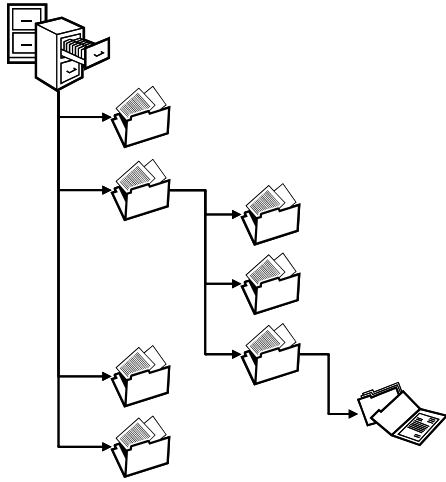

Project documentation provides the means by which information and ideas are created and shared, and it is the basis upon which decisions are made and approved. Project document management is defined by the practices and procedures used to create, distribute and store various types of project documentation. A project needs to define the structure by which it will organize its project documents and develop a simple method for its

management. To accomplish this objective the projects will start by defining some basic goals.

6.5.4.1 Document Management Goals

- To provide a mechanism for document production and control that does not add substantial overhead to the project process.
- To provide standardized formats and templates for document production.
- To promote collaboration and consensus through a structured process for document review and approval.
- To facilitate document retrieval and accessibility
- To minimize documentation errors through version control and secured access.
- To ensure that all documents are current and that distribution is timely.
- To maintain a tangible record of project strategies, activities and decisions, for future reference and lessons learned evaluation.



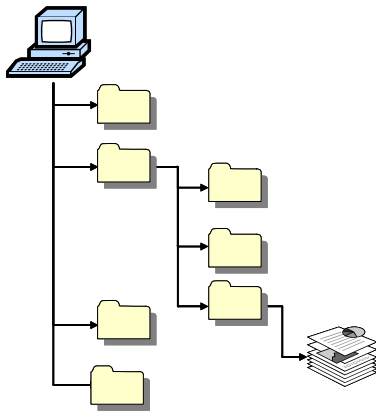

































6.5.4.2 Document Management Elements



From the most complex system to the simplest filing cabinet, document management tools rely on a standard premise which is: all documents must be created and stored in an organized fashion, designed for easy access and control. As such, any document management system must address the following elements:

- **Input:** The means by which documents are created and placed into the system. Project document repositories may hold original documents that are created by the project team, as well as external documents produced outside the team, including reference materials (i.e. technical manuals or contracts).
- **Access:** The means by which access is granted and controlled. (shared drives, folders, intranets)
- **Collaboration:** The means by documents are reviewed and revised based on collaborative (team) reviews, input and edits.
- **Version Control:** The means by documents are tracked for changes over time. (Version 1.0, 1.1, 2.0, 2.1, 2.2, etc.). Document versions offer a visible trail of project changes and progress, and ensure that everyone is literally working "on the same page".
- **Output:** The means by which documents are retrieved from the repository and distributed in print, HTML or email (or other applicable format).
- **Searches:** The means by which documents can be found and searched (i.e. according to keywords or for specific information).
- **Archival:** The means by which documents can be stored and retrieved for future reference.

Example of a Simple Document Management Taxonomy

 PROJECT BOL622
PROJECT INITIATION
 Project Contracts
 Donors Contracts
 Partners Contract
PROJECT PLANNING
 Project Diagnostics
 Project
 Project Baseline
 Project Baseline
 Project Plans
 Project Schedule
 Project Logframe
 Project Objectives
 Project Work Breakdown Schedule
PROJECT EXECUTION
 Project Implementation
 Project Meetings and Resolutions
 Project Activities
 Activity Assignments
 Activity Progress Reports
 Project Stakeholder Information
 Project Beneficiaries
 Project Partners
 Project Donors
 Project Human Resources
 Project Staff
 Project Task Assignments
PROJECT CONTROL
 Project Budget
 Project Budget Contracts
 Project Expenses
 Project Financial Reports
 Procurement Logs
 Procurement Schedules
 Inventory Reports
PROJECT CLOSEOUT
 Project Evaluations
 Project Midterm Evaluation
 Project Final Evaluation
 Project Internal Evaluation
 Project External Evaluation

6.5.4.3 Project Document Management Plan

Step One: Delegate responsibility and accountability.

Every mid-sized to large scale project should have a Document Repository Coordinator. Depending on the number of documents, this may be a full-time role or a shared responsibility, but the "role" itself is essential. The Repository Coordinator should be responsible for the following:

- To identify needs and establish project documentation procedures.
- To set-up and maintain the document repository.
- To respond to issues and questions.
- To provide assistance to team members.
- To ensure that documentation policies are enforced.
- To manage document archival once the project is complete.

Step Two: Identify project documentation management needs.

- What types of documents does your project require? (considering research documents, project initiation documents, project plans, contracts, policy documents, work specifications, technical documents, forms and reports).
- How and when are these various documents used within the project process (what purpose does each document serve?)
- Who authorizes the release of these documents?
- Who will have input into these documents?
- Who will need access to these documents?
- How do these needs and requirements apply to projects of different sizes, complexity and visibility?

Step Three: Set documentation standards.

Documentation standards should be designed in accordance with technical capabilities, and scaled to suit project size and circumstances. The goal is to save time and promote consistency by standardizing the "look and feel", while providing content guidelines to ensure that all documents convey essential information. As such, any established documentation standards should address the following issues:

- What software will be used to produce the various types of documents?
- What formats will be used for each type of document?
- Will documentation templates be provided according to project needs, size and complexity?
- How will documents be classified for security purposes (i.e. Confidential, Public, Departmental, Internal)?
- How will documents be distributed outside the repository (i.e. email, web, print)?

Step Four: Develop your document production cycle and workflow.

The document production cycle and workflow provides the structured process by which documents are created, revised and approved. Since project documents represent tangible proof that project decisions and strategies are underway, any productive workflow should be designed to ensure that these documents are created in collaborative manner, and distributed for timely approval and acceptance. A basic documentation workflow can be laid out in five specific phases:

Phase 1: Document Draft	The document "draft" is prepared according to established standards and formats
Phase 2: Document Review	The "draft" is reviewed by all appropriate stakeholders, and input is offered.
Phase 3: Document Revision	Review comments are considered and document revisions are made. A "pre-approval" version is produced.
Phase 4: Document Approval	The "pre-approval" version is distributed to all appropriate stakeholders for document approval and acceptance. Further revisions may be necessary at this point. Once all approvals are secured, the document becomes "final", and is part of the project record. However, as the project progresses this "final" version will still be subject to changes should project circumstances warrant. These changes will be implemented according to established version control procedures.
Phase 5: Document Distribution	At times, project documents may be distributed outside of the project document repository (i.e. to the general end-user community as project updates and general reference information).

6.6 Reporting and Sharing Information

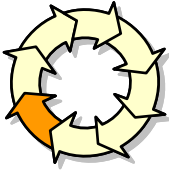

As important it is to collect the right information, it is also important to report the information to the right people at the right time. There is no value if the information doesn't reach its intended audience. By reporting and sharing, the information's value grows as other projects or stakeholders can benefit from the findings and insights the information is conveying.

The information held within a project is central to its achieving key targets and objectives and ensuring positive collaboration and strengthening relationships amongst its beneficiaries and partners.

In order to be most effective, information needs to be easily accessed, shared and combined to provide maximum benefit to those who need it.

- Correctly describe and identify the information assets so that it will appear to have benefit to the project.
- Develop a culture that not only encourages the sharing of information but also encourages project staff to seek advice and assistance from others outside of their own immediate environments.
- know what systems, both electronic and human, need to be put in place in order to ensure the efficient flow and distribution of knowledge

6.6.1 Identifying the means to share the information

The means to share information are the methods chosen by the project that will make the project information available to its final users on a timely manner. The means available range from a meeting or group presentation to a publication in a local newspaper. The project needs to identify how each one of its information assets will be shared with its different stakeholders.

Another consideration when defining the means to share information is that not all audiences are the same and one piece of information shared with different groups or audience may have

different interpretations. The project needs to be conscious of the audience it intends to share information with.

Sharing methods	Good for	Key audience
Physical means:		
▪ Group presentations	Training materials	Project participants, beneficiaries
▪ Newspaper	News, pictures, reports and advertising	General public
▪ Handouts and pamphlets	Directions, instructions, marketing	Communities and general public
▪ Books, journal	Evaluations, case studies, guidelines, instructions	Development workers, researchers
Electronic means:		
▪ Web Sites	Studies, research articles, pictures, reports, evaluations, marketing, training.	Public in general
▪ Intranets	Studies, research articles, pictures, reports, evaluations	Organization and other program staff.
▪ Audio/Video	Instructions, training, documentaries.	Targeted audience.
▪ Email	Short messages with small attachments containing	Targeted audience, project staff, management, donors
▪ Discussion Forums	Questions and answers, resolve and agree issues	Can be private as well as public.
Other means		
▪ Radio	News, marketing, announcements	Targeted to radio audience in a community or city.
▪ Television	News, marketing, announcements	Targeted to TV audience in a community or city.

6.6.2 Structuring Information

A good approach is to structure reporting from the field so that aggregates or summaries are made at intermediate stages. In this way, field staff can see how averages or totals for specific villages or districts enable comparisons to be drawn and field-work improved. Surveys and studies. To measure output and impact may require the collection of data from sample surveys or special studies (including, where appropriate, participatory methods). Studies to investigate specific topics may call for staff skills and training beyond those needed for regular collection of data to create a time series. Where there is a choice, it is usually better to piggyback project-specific regular surveys on to existing national or internationally supported surveys than to create a new data collection facility.

6.6.3 Data Analysis

A project can implement a variety of processes to ensure that reported information is complete and accurate. These can be divided into two broad types:

- Procedures for editing, testing and analyzing that are incorporated into day-to-day operations
- Procedures for editing, testing and analyzing that are designed to be used for specific reporting purposes and that are implemented on or near the time the project is required to report the data

Generally, the more verification that can be incorporated into a project's regular data-generating activities, the better data the project is likely to produce. Project information is accessed by various users on a regular basis for decision making purposes. Users should have confidence that a project's database is as correct and complete as it can be at any time the user needs the data.

Another reason to incorporate editing and analysis into everyday activities is that it is much easier and more efficient to identify and correct mistakes on a current basis rather than on an historical basis. Furthermore, most projects will find handling large data delivery projects easier if the information is collected and reviewed on a regular basis rather than all at once before the reporting deadline.

The DME-IS reporting process needs to include ways in which day-to-day data review and analysis can be combined with one-time review and editing to provide accurate information. For example, if a project collects and processes beneficiary information in an appropriate format on a daily basis and reviews the data at the end of each period reporting period, then the process of data reporting is simplified.

Problems and inaccuracies are corrected at the end of the each reporting period when the personnel who collected the data are more likely to remember what caused the problem. When the information is due, the project simply completes the final period as usual, edits the data, and reviews each reporting period for reasonableness. This process is more likely to result in fewer errors than a process that attempts to correct data for the year on or near the final evaluation deadline.

Editing, testing and analysis procedures can take many forms. For automated systems, a project can incorporate rules that look for valid data entries, valid combinations, entries outside of specified ranges, etc. Automated and non-automated systems require reasonableness checks and periodic data analysis.

6.6.4 Reporting the Information

The most visible part of an information management system is the reported data that is generated. Project staff, partner organizations, donors and the beneficiaries form opinions and make decisions based on the information reported by the project. A project therefore should strive for timely, comprehensive and understandable reporting mechanisms and formats.

For internal reporting, the most critical elements may be timing, accuracy and completeness. Day-to-day operations depend upon a regular flow of reliable information. The project manager may need a monthly analysis of project progress and critical issues to make planning decisions. Country Directors and program managers need reports to compare plans with actuals so that budgets are not overspent. A project should spend time training its staff to read internal reports and documents necessary to perform their jobs.

Timeliness, accuracy and completeness are just as important for external reporting as for internal reporting. However, the format or manner in which information is presented becomes much more important. The format may be determined by a donor agency (for example, the formats required by USAID). In this case, a project must take pains to report in the required manner. Reporting in the manner prescribed may involve activities such as programming changes, staff training and/or technology changes.

For external reporting with no mandated format, a project's primary consideration should be what information it desires to convey and to what audience it is presenting the information. For example, a presentation to country office executive members about a project's current progress may be more technical in nature than a similar presentation to beneficiaries.

6.6.5 Defining the formats to present the information

Information Type	Format	User	Specifications
Project Information Reports	Word Document, using standard country office format	Program Director	Send zipped in version MS Word 2000. via email with size less than 500kb
Training Material for Beneficiaries	Pamphlets and one page instructions	Beneficiaries	Large pictures and charts in colors.

6.6.6 Defining the level of detail required.

The detail presented in the information needs to serve a purpose, in some cases the information users has little time to read and a quick graphic in one page would suffice. In other cases the information user is an analyst or evaluator who will require more detail in the information to conduct its own analysis and conclusions from the information. Each information user or audience has a different requirements as to detail of the information, It servers no purpose to send a lengthy manual of 200 pages to a project staff who needs information that can be summarized on 5 pages or less.

6.6.7 Sharing the information

Internal information sharing is vital for the efficient operation of a project information system and the provision of high-quality services to donors and stakeholders. Information must be seen as an organization asset and the existence of 'information silos' discouraged. All project information sources should be regarded as shared unless there are legitimate reasons for restricting access to a particular group of staff.

6.6.8 Using Information at the Project

Information is not a product the project creates only for donors or external stakeholders, all the information needs to be used by the project. Make the information visible to all staff by posting the information available in the form of charts, graphs, in the project walls and other areas for all to see it. Project staff need to be informed as well on all elements of the project. The key information that needs to be visible to all are:

- o Project Logframe

- Project Objectives
- Schedules (updated regularly)
- Progress charts (indicators)
- Pictures of project activities and beneficiaries
- Maps of the areas where the project works
- The Organization mission and vision and its core values.

6.6.9 Information Sharing vs. Information Hoarding

It is common to think that information sharing is always better than hoarding information. However, sharing information just for the sake of sharing must have a purpose at its root. Sharing information should support decision making or propel innovation. There must also be a structured process by which to capture and use the information being uncovered.

Information hoarding is the other extreme. Information and knowledge still represent power. Hoarding is not always a conscience act of holding back information, encouraging and providing an incentive for people to share what they know will show returns to the project via an increased base of knowledge. Hoarding information results from a lack of trust, the project needs to focus on strategies to begin a productive information sharing environment.

6.7 Using the Information

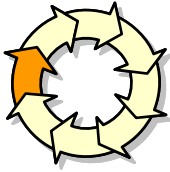

The highest value from information comes when it supports decision to improve the project, by modifying strategies, approaches, methods to get the project closer to its objectives. Not using information, after all the effort of collecting, organizing and reporting is akin to having all the gauges and dials on a car and all the road signs and maps and not using them. With out this information it is impossible to know if we are getting closer to our destination. Using the information we can now how closer we are to our objectives, what changes we need to make to correct any deviations from our original plan or what opportunities are ahead of us to help us get to the destination.

It is not uncommon for project to collect huge amounts of data and never use it (a symptom of poor project information planning). And not unusual for a project evaluator to find out that the project has been collecting the wrong type of data. Using information validates and justifies the cost and effort of collecting it. It is from the use of information (information in action) that we can gain knowledge from the project.

There are many uses of project information and these should not be confined to the uses a donor makes of it, but to the uses and value the information can bring to the project and to its organization

6.7.1 How is the information used?

There are three main categories of information usage, these are: decisions, compliance and knowledge.

Decisions are made on information that tracks progress to make changes in the strategies and approaches the project has chosen initially. This type if information includes project reports, evaluations, baseline information, etc. These information types are used by management, community leaders, donors and key project stakeholders. Other type of information needed for decisions may include changes in the project environment that will impact its operations , information such as migratory changes of beneficiaries, political unrest.

Main use of information in this category is to monitor projects performance in the utilization of its schedule and budget to meet the expected outcomes and objectives. If deviances are found then the project will need to make corrective actions.

Evaluators use information on the effectiveness of the project in meeting its goals.

Compliance is information used to meet legal or contractual requirements that the project has responsibilities for. These include information to the donor, information to the local governments to meet local laws, information requested by CARE headquarters to help is the development of strategies. Donors use much of the information sent to them to also report back to their own supervisory boards.

Knowledge, information is also used by other external parties to gain on the experiences of the project. Knowledge is also gained by the project itself in its process of implementing actions in the field as it evaluates and learns from its actions. Information is also used as a tool to communicate and educate beneficiaries, promote and influence positive changes.

6.7.2 What decisions were taken from the information?

The information leads to decisions and actions that will help the project meet its goals. All the decisions taken are based on the quality of the information, and thus the quality of the decision will be influenced by the quality of the information. The decisions in most cases will be corrective actions to refocus the project objectives, either by changing strategies or approaches. In other occasions the decisions will be to increase the inputs or activities to meet the project schedule. Projects need to have an inventory of all the decision made and the information that was used to support the decision.

Making decisions is not a single activity, it consist of several different activities that take place at different times and has different influences and uses many information sources. For decision to be made the problem needs to be well understood and thus managers need to have access to good information on a timely manner. The project needs to provide the right information for stakeholders to know how well the project is performing and where the problems exist. Once the problem is identified a solution needs to be designed and even here more information may

be needed to ensure the solution fits the appropriate context. Once different solutions have been designed the next step would be to choose the best solution and implement it. Here is important to have information to track the progress of the solution and identify any potential problems, difficulties and define possible ameliorative actions.

The design of the project's DME-IS, needs to take in consideration the different stages that occur in the decision making process and design the system with enough flexibility. An important role of DME-IS is not to make the decision for people but rather support the decision making process. A DME-IS should have the following characteristics:

- Flexible and able to provide many options for handling data and evaluate the information.
- Capable of supporting a variety of styles, skills and knowledge
- Capable of changing as project staff learn and clarify their roles.

6.7.3 Is there any information that was not used?

The value of information is in its utilization, if a piece of information is not being used, then the project needs to ask as to the value of continuing its collection. If the information is not used for decisions, compliance or knowledge then it is not needed. After each cycle of information process the project will determine what information stays and what information needs to be left out of the next information management cycle.

6.8 Evaluating the Process and the Information

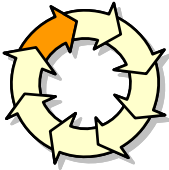

For an effective system the DME-IS needs to go through periodic reviews, necessary to maintain its quality and effectiveness. Evaluating the system can occur at any time or during project evaluations. The process to evaluate the DME-IS needs to be inclusive of all stakeholders and uses the feedback from information users as a first step to identify improvements. The main goal of evaluation the DME-IS is to check on whether or not the system is providing the information needed by the project stakeholders.

The objective of the evaluations is to streamline the information process, by reducing the time and effort it takes to produce results, eliminating redundancies or overlaps in process and information, and identify opportunities to increase its impact to the project.

6.8.1 Evaluate the process to manage the information

To maintain the effectiveness of the system the project will need to make periodic reviews through the life of the system. The evaluation is a validation of the DME-IS as a tool to help the project meet its objectives and its also an opportunity to review the process with other project stakeholders. As part of the validation the project will need to answer the following questions:

1. Does the project staff understands the use and purpose of DME-IS?
2. Is the information requested being collected correctly?
3. Does the information reaches all stakeholders?
4. Is the information being used correctly?

By evaluation the process the project needs to look for areas where the process has "bottle-necks" or areas where the information takes too much time to process, whether in its collection or distribution. Look at all the 9 components of the information process to identify the areas that may need improvement.

1. Evaluate the process to **Identify** needs, Have all needs been captured, are any needs still not being accounted for?

2. Evaluate the process to **Locate** information. Have new sources of information been discovered? Are the original sources still available?
3. Evaluate the process to **Select** the information. Is the information still relevant, significant, useful, accurate, credible and cost effective?
4. Evaluate the process to **Collect** the information. Is the volume of information too large to manage? Are the methods and techniques to collect information still valid? Do we need to change the frequency, format and responsibilities to collect information?
5. Evaluate the process to **Organize** the information. Do we need to change our methods to organize the information? Do we need to change the tools to store the information? Has the security of the information been compromised?
6. Evaluate the process to **Report** the information. Do the means to share our information need to change? Are the users receiving the right information on time? Are the formats to report information adequate and accessible by the users? Is the level of reporting detail adequate?
7. Evaluate the process to **Use** the information. How is the information being used? Is there any information that is not being used at all? How is the information helping the project meet its goals?
8. Evaluate the process to **Evaluate** the information. Are we evaluating correctly? Do we need an outside expert? Have we received feedback from all stakeholders?
9. Evaluate the process to **Improve** the information process? Are we implementing the changes to the project? Have the changes resulted in actual improvements?

6.8.2 Analysis of gaps in the information collected.

Identify the gaps between the original plan and the results we received from the process, and make any modifications to close the gap.

These could be found at the moment of making analysis of the data received and comparing the analysis to the original questions asked by the project. If a specific project indicator was asking to monitor the number of children that receive vaccinations and disaggregate the information by gender and age, at the moment of analysis the project may discover that the data collected only accounted for gender and not age. Make the nec-

essary changes to the process, forms and reports to include this data for the next cycle.

Gap analysis identifies the differences between the current state with the ideal or desired state.

6.8.3 Lessons Learned

The projects needs to have a formal process to capture the lesson learned in the information management process of DME-IS. This process ensures that project staff are able to express their opinions about the areas that need improvement for the next project cycle (or improvements for the next project). The process to capture lesson learned needs to be simple and inclusive and it's a great opportunity for learning and improvement. It is not an opportunity to lay blame and finger-pointing for any problems,

Lessons learned processes are meant for sharing and reusing knowledge gained through experience. These can be motivated by the need to preserve a project's knowledge and convert individual knowledge into organizational knowledge so that other staff who encounter conditions that closely match some lesson's context may benefit from applying it. Therefore, a lesson learned is a validated working experience that, when applied, can positively impact an project's information management processes..

The methodology follows a process in which the team first identifies what have been the strengths of the DME-IS, then lists the areas of weaknesses of DME-IS. The team brainstorms the solutions to improve the process and develops an action plan to implement any changes to the process. The lesson are documented for other projects to take advantage of the experiences and knowledge the project produced.

The project needs to document the causes of variances and the thinking behind the corrective action in order to enhance its ability to respond to future project challenges. The project enhances its ability to deliver its information by learning from previous experiences. The following are some guidelines to capture the lesson learned.

- Capture and share lessons learned at the end of project phases rather than only at the completion of the project

- Capture lessons learned as close to the end of a project phase as possible or you might lose some key lessons
- Lessons learned can be used to mitigate risks on future projects.
- Incorporate lessons learned into the closeout phase of the project.
- Call the project team together to brainstorm/identify lessons learned, they will build on each other's thoughts.
- Establish a process for communicating lessons learned to others in the organization that might benefit as well.

The project manager can act as a facilitator in the lessons learned meeting to help the project team capture the project's lessons learned. The goal of Lesson Learned is to ask what would you change, add or delete if you had to start the project all over gain. This is what the project has learned and these lessons need to be shared to a wider audience.

6.8.4 User's expectations

A key indicator of the effectiveness of the DME-IS and the Information management process comes from the actual users of the information. The project needs to capture or understand the user's satisfaction to the timeliness, quality and relevance of the information they have received from the project. Users are not only the external stakeholders of the project, but also the internal users in the project who use the information to guide them reach the project objectives. Interview users as to the expectation they have with the information they receive from the project. Take note of any needs not captured by the project, explore potential new uses for the information as related to the needs of the user.

The final evaluation comes from the information user, as the information serves its needs not only to be informed but to act based on the information received. If the information is late, of poor quality, not relevant or in the wrong format, the users will not be able to act on it or the actions taken may result in negative outcomes to the project and result in serious consequences to the credibility of the user and the project. A project reporting that enough children have received vaccination (an information later discovered not to be true) may cause the users or decision makers to stop the activities of immunization. This can cause serious health risk to the few children that missed the immunization because the information provide by the project was wrong.

6.9 Improving the Information Process

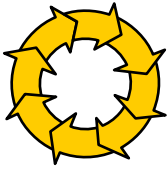

The goal of evaluating the process is to ultimately improve the process. Not good can be obtained by an evaluation report if no actions are taken to implement the changes and make improvements to the process so that the next project or information cycle produces better results. By improving the information life-cycle projects can achieve a reduced cycle time, information reuse, cost savings and greater stakeholder satisfaction.

The objective is to continually improve everything in the process by encouraging everyone to take responsibility in the process.

6.9.1 Improve the process for the next cycle

Every project cycle is an opportunity to review and improve the DME-IS process. It is at that moment that staff have fresh memories of what went wrong and how to fix it. Waiting too long may cause that improvements are never done or done partially. List all the recommended improvements and rank them by its feasibility and impact to the project. It is not necessarily that the projects seek to implement all the recommendations for the next cycle, by concentrating on the 20% most needed changes the project could achieve an 80% improvement in its information management process.

6.9.2 Modify the Process.

Review the steps in each process, evaluate the changes needed to the documentation, guidelines, flowcharts and other tools used in the process. Make the required changes and properly inform all stakeholders on the new changes. Train all staff on the use and application of the new changes and if possible pilot the changes before its full use.

6.9.3 Implement the new changes

Inform all project information users; donors, beneficiaries, partners, local governments and the organization's management on the new changes. Inform accordingly to the changes each users will see in the process. If an user will not be impacted by the change then there is no need to inform.

If time and resources allow it, pilot the changes before its full rollout, this will give the project an opportunity to test whether or not the changes are feasible and do indeed meet the objectives the changes were designed to achieve (quality, reduction in process time and effort). This is also useful when the changes include changes to a software database application.

Make an effort to document the changes to track the modifications made to the whole process, this can be useful when auditing the system.

6.9.4 Information Management Maturity Model

This model shows the different levels of information maturity for any project. Each project goes through a series of improvements and enhanced to its information process in order to meet stakeholder's expectations of quality information. This model can help in identify the current state of the project IM level in order to define what needs to be done to achieve an optimal level.

Level	Characteristics
Level 1 Informal	Characterized by a lack of structure and uniform practices. Each individual follows a unique process and applies standards independently. The quality of the information is highly dependent upon the professionalism and expertise of the individual. No quality assurance activities take place except for reviews for information accuracy. There is little opportunity to study stakeholder's needs.
Level 2 Rudimentary	Starting to establish structure and uniform practices. At a grass-roots level, staff establish data collection standards and institute uniform practices. At a management level, the project begins to establish best practices. Often characterized by beginning to institute quality assurance practices, including quality reviews. Rudimentary new practices are often abandoned under pressure of deadlines and constantly changing requirements, as well as a lack of commitment among the project staff to changing individual practices.
Level 3 Organized	Dedication among the majority of project staff to uniform best practices and standards. Practices begin to take on a customer focus. Planning and quality assurance activities are stressed and are incorporated into every project phase.
Level 4 Managed	Characterized by a stable commitment to planning, quality assurance, hiring and training, and controls. Level 4 projects become increasingly sophisticated in handling beneficiary data, assessing and meeting stakeholder needs. Recognized as effective by the organization and donor agencies.

Level 5 Optimized	Characterized by innovation beyond the stable commitment to mature practices. At this level the project continually calls into question its own practices and standards, continually seeking ways of meeting stakeholder's needs more effectively, reducing process and costs, and achieving a superior information output.
----------------------	---

Each project should be able to locate its information process in one of the above levels, and seek to reach level 5.

A continuous process to improve the project's DME-IS should be part of the normal routine in the project's management cycle. Information is at the core of what a project manages to reduce poverty and bring change to the communities it works for.



"Information, defined as knowledge in communicable form, is recognized today as one of the main requirements for development. Indeed the ability to record and use data, information and knowledge is one of the most important human characteristics." - Unesco



Chapter 7 Information Plan

7

7. INFORMATION PLAN

"If you fail to plan, you plan to fail."

".. A major weakness is the ability of project staff to utilize their log-frame for designing a coherent and integrated, overall information system, where a manageable and limited number of feasible information activities are planned, which together will ensure that effective effect and impact level monitoring will occur. It is typical for projects to end up collecting too much rather than too little information. Frequently though, much of this information is not relevant to monitoring the results and impacts for which the project is accountable, and that which is, is not collected sufficiently reliably or regularly. By restricting the number, but improving the quality and reliability of their major information gathering activities, projects will much improve their information systems." CARE International EDIAIS Case Study

Detailed planning is critical to the development of usable, high quality information deliverables that meet the needs of internal and external information users. The project team needs to discuss the content and structure of the overall project information plan. In this plan, the team will analyze the purpose, audience, design issues, media and technology constraints, and development environment for the project. The overall project information plan also includes an initial specification for each individual information output.

The Project information plan is a document that defines the actions and responsibilities to manage project information. Developing a plan is an essential step in determining the effort and time that will be required to collect and distribute project information. The plan should address the following areas:

1. Information Requirements - What data must be available and to whom?
2. Information Collection - How will Information be collected?
3. Information Analysis - How will data be edited, tested and analyzed?

4. Reporting Information - How will Information be disseminated?
5. Historical Information - How will historical Information be maintained?
6. Access to Information - How will Information be secured from unauthorized access?
7. Personnel - The roles, responsibilities, qualifications and training of the personnel necessary to implement the plan
8. Technology - The technology necessary to support the plan's goals and objectives
9. Internal Controls - The internal controls necessary to ensure the plan is working.

Management of information is a critical component in the overall management of a project. A project's ability to provide accurate, timely information to a variety of audiences may significantly affect the relationship the project has with its staff, management, beneficiaries of the project and outside funding agencies. In addition, the quality and accuracy of information reported to donors and other governmental entities can affect a project's funding, a project's credibility and the public's perception of a project.

A project information management strategy should be developed which will specify how information is created or collected, maintained, reported and stored. This strategy and the project's information management system should be designed to provide answers to two basic questions:

- Is information being collected, processed and stored?
- Is information being reported and distributed appropriately?

All projects have an information management system; it may be informal and undocumented or formal and documented.

Management of project information should be incorporated into the project's comprehensive information management system which includes all of a project's information needs. A project's information management system should address the use of both technological and human resources.

7.1 Introduction

A successful DME-IS usually requires creation of a formal, documented information management plan. Elements of such a plan describe:

1. *Information Requirements* - What information must be available and to whom?
2. *Information Collection* - How will information be collected?
3. *Information Analysis* - How will the information be edited, tested and analyzed?
4. *Reporting Information* - How will the information be disseminated?
5. *Historical Information* - How will historical information be maintained?
6. *Access to Information* - How will information be secured from unauthorized access?
7. *Personnel* - The roles, responsibilities, qualifications and training of the personnel necessary to implement the plan
8. *Technology* - The technology necessary to support the plan's goals and objectives
9. *Internal Controls* - The internal controls necessary to ensure the plan is working

Establishing a written plan can help a project maintain control over its information management system. It provides a framework that can be useful to a project in the process of achieving its goals.

Creating an information management plan is not a one-time task, as the maintenance of the plan is a dynamic process. The plan should be constantly revised as circumstances dictate to incorporate a changing environment and to address existing problems. For example, the internal controls established by the plan may indicate that some parts of the plan are not working. Also, information and technology needs change over time and the available technology changes. With a documented plan, improvements or changes can be identified and readily incorporated into the system.

As an element of this dynamic process, the information management plan and all subsequent changes should be made available to all

stakeholders affected by the plan. A project should encourage those who create and use information to become involved in correcting and improving the project's information management system

7.2 Information Requirements

To develop an information management plan, a project must first determine its information needs. All information needs are determined by the types of information it must maintain and the users who require access. A project's best interests are served with a thorough understanding of the needs of all internal users and as many external users as possible (other agencies, the public, etc.). Such identification allows for customization of the plan based on specific requirements.

A project's data needs are dictated by:

- Legal and regulatory requirements imposed by donor and local governments.
- Requirements imposed internally by headquarters and regional management.
- Beneficiary and partner demands for information
- Internal operations

Each of the above areas should be examined in detail to specify the project's information needs. In this examination, consideration should be given to both short-term and long-term needs and both regular ongoing and temporary needs.

These requirements should be gathered from beneficiaries, partners, government agencies, other organizations. For example, staff members responsible for reporting to donors will be most familiar with the requirements of these donors. For internal operations, each staff member's data requirements are dictated by the staff member's responsibilities. The person most familiar with the job will be able to specify the information needed to do the job efficiently and accurately. The increasing reliance on site-based decision making generally means that more information must be made available to more people. By including staff from all areas of a project in the development of the information management plan, increases the chances of the plan's success.

After these requirements are gathered, it should be analyzed and compared to the project's current efforts. In particular, a project should look for duplication of effort (for example, multiple staff members citing responsibility for reporting identical information), requested information needs that do not match a staff member's level of authority and obvious omissions in the project's information needs.

The project needs to develop a document that details the project information needs, both internally and external. Detail in the document; who needs it, when they need them, how they need it and what uses will be given to the information. The project can use this matrix to rank the priorities and relevance of all information needs.

7.3 Information Collection

After information needs are identified, a project can determine sources for the various types of information and specify how the information will be collected

7.3.1 Information Sources

The information management plan must identify an appropriate source for each type of information required. A project acquires information from both internal and external sources. For all sources, the plan should describe how the information will be collected and stored.

If there are multiple sources for a particular type of information, then sources must be judged based on efficiency, accuracy and how close the source is to the origination of the information. A direct flow of information is generally the most efficient and the most accurate. The project should determine the most efficient source and modify its information collection procedures if a proposed source is more efficient than the existing source. For example, if one project manager currently receives country statistic information from another project manager who receives the information from the main office, it may be more efficient for the main office to provide such information directly to all project managers. This direct flow ensures that all managers receive the same information in the same time frame and reduces the potential for information to be miscommunicated.

A project should also ensure that duplication of effort does not occur in the collection of information. As much as possible, a project should strive to have a single source for each information type. If a project maintains multiple data bases for beneficiary surveys (records maintained by the project staff and separate records maintained by the partners), the possibility of problems relating to accuracy and consistency of beneficiary reporting may increase.

7.3.2 Collection Issues

The project's information management plan should address the following:

- How will information be collected?
- Who is responsible for the collection of information?
- When will information be collected?
- In what format will information be collected?

The method for collection depends on the type of information and how it will be utilized. The plan should assign collection responsibilities to specific staff members to ensure that expectations are clearly understood and that duplication of effort is reduced.

The plan should incorporate reporting deadlines when appropriate and establish time frames for all collection tasks. It should clarify which time frames include due dates that are fixed and those that are simply target dates.

For collection activities that require data to be collected or reported in specific formats, the plan should either specify the format or refer to the source documents that provide the information.

A project may use a variety of documents to address these issues. Timelines, charts, checklists and information flow diagrams are a few examples of documents that may be useful. Some of these documents require frequent or periodic updating. For example, a timeline that includes major project events will be replaced with a new timeline each year.

7.3.2.1 Collection Issues

The timeline should show reporting requirements in chronological order. This schedule can identify a project's peak information reporting periods, down times, deadlines and overlapping events. During the planning process, potential problem situations identified can be dealt with in a timely manner. A timeline that includes external reporting dates allows a project to establish internal due dates for the creation or sharing of information. For example, based on a project's fiscal year deadlines to its donor and to headquarters, the project can establish essential internal deadlines for submission of designated elements of DME-IS information to the project's DME-IS coordinator.

In certain instances, a project may not control overall aspects of the timing of information collection activities for reporting information to external organizations. For example, a project may rely on the local government own timelines to publish reports.

The uncertainty that exists in such situations can make planning difficult. A project may still establish detailed timelines and checklists for the annual processing of donor reports despite this uncertainty. However, there is a certain amount of risk that the external agencies will not make information available within the time frames established by the project's schedule.

A project should include dates for such activities in its information planning timelines even if the dates are estimates. Dates help ensure that critical deadlines or events will not be missed and to provide a framework for change, if necessary. For example, a project may have established time frames for Donor report preparations but then discover late in the calendar year that additional information will be required for reporting. Since the project already has a plan with established time frames for the preparation of the report, it should be easy for the project to analyze the effect of the new requirements and to make adjustments to comply with the requirements.

The chart below reflects an example of a timeline highlighting major project activities. These timelines can be a useful component of the information management planning process.

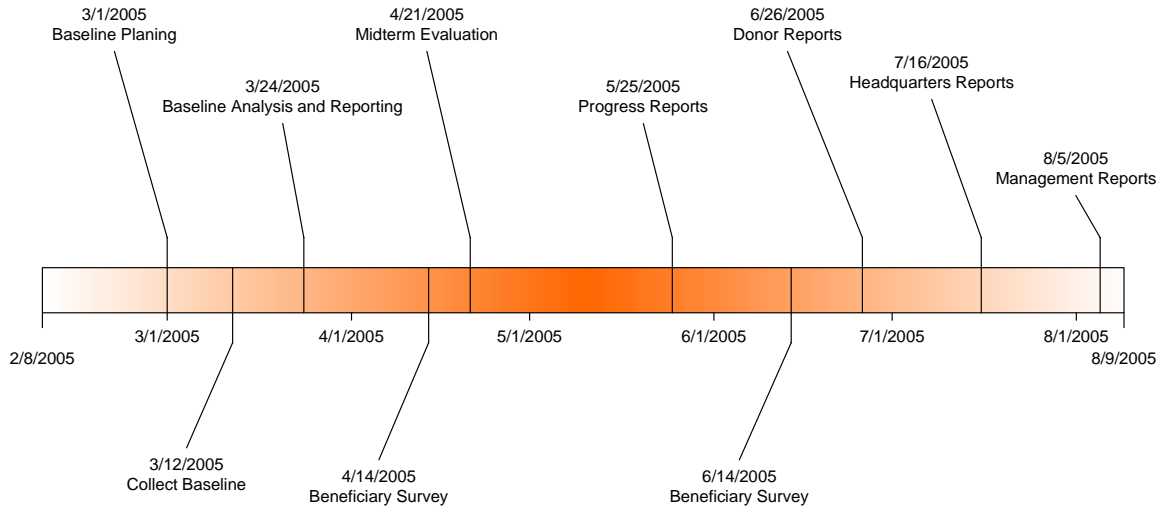

Figure 34 Example of a Timeline of Major Events for a Project Information Needs

7.3.2.2 Resource Aids

Utilization of project planning tools can enhance the information management process. The use of charts such as project evaluation and resource tracking charts (PERT) and Gantt charts can be valuable to graphically display process flows, timelines, tasks and the interrelationships. Staff members involved in the design of the project's information management system should become familiar with these chart types which can be very useful tools for information management planning.

PERT charts can be used to depict the interrelationships among the tasks that make up a project. The format is similar to a flowchart. Each box or ellipse within the chart represents a task; connecting lines or arrows show the relationships between the tasks. This chart is very helpful in depicting work flow and interdependencies between tasks. The chart clearly shows which task or tasks must be completed before another task can begin and which tasks can be carried out simultaneously.

For example, a PERT chart might be used to depict the work flow and critical paths for the Donor Report submission. The chart can help staff members see the tasks they may begin before other tasks are completed, the tasks that cannot begin until after another task has been completed and that some

tasks can occur simultaneously. The chart below provides an example of a PERT chart for this type of project.

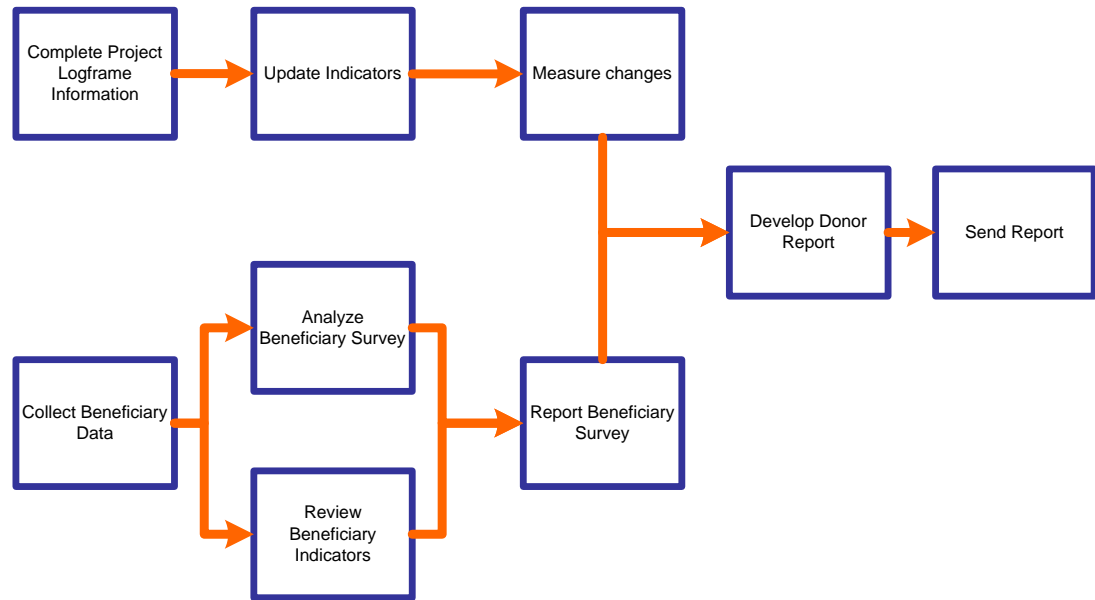

Figure 35 Work Flow PERT Chart

A Gantt chart is a graphic representation of a project's schedule. Each task within the project appears as a bar. The bar's length represents the task's duration. The starting point indicates when work on the task can begin. At the beginning of the project, the chart shows the estimated times for each task. During the project, the chart can be updated to show the actual time a task was completed. A Gantt chart shows whether a project is on schedule signaling modifications that should be made to the project to provide resources to make up for the time lost.

The chart below shows what a segment of a Gantt chart for a project might look like. Note that the Gantt chart shows both the anticipated times needed to complete each task and the interrelationships between the tasks. If a task early in the project falls behind schedule then adjustments must be made in the time allowed for later tasks (updating staff responsibilities) if the project is to be completed on time and meet the due date.

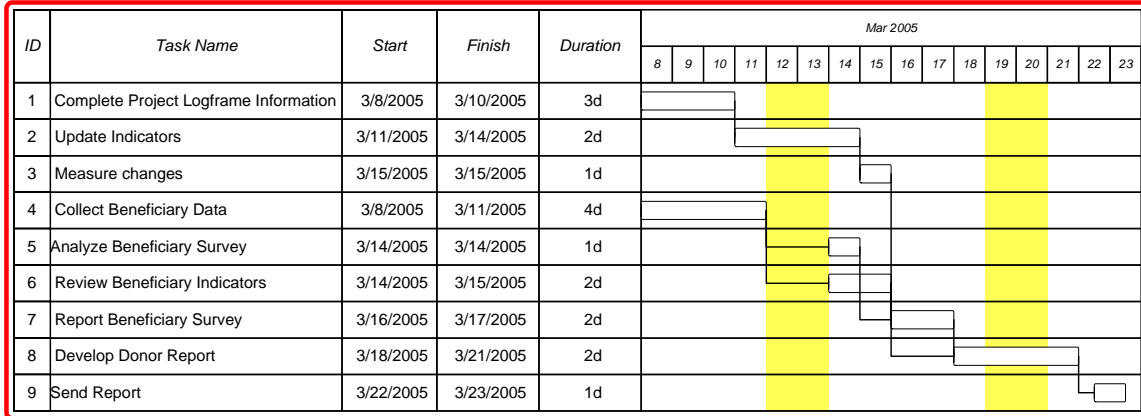

Figure 36 GANTT chart Information Schedule

7.3.2.3 Checklists

A checklist is another useful tool in information planning. Some data collection and reporting activities in the project’s timetable require a very detailed breakdown of the steps necessary to accomplish a task. In this situation, a checklist of the steps required may be useful. The checklist should list each step in the process, the person(s) assigned to do the task and the date the task must be completed. A checklist:

- Assists a manager in tracking the status of the project
- Informs staff of task and time expectations
- Provides a measure of assurance that steps will not be omitted
- Provides a framework for tasks to be done in a logical, efficient manner
- Assists with time management
- Provides feedback that may indicate problematic aspects of a project

The chart below is an example of a checklist that might be created by a DME-IS coordinator in preparation for donor report submission.

Task	Responsible	Planned completion Date	Actual completion Date
Distribute project's information requirements			
Train staff on use of DME-IS			
Establish due dates for donor reporting			
Design Baseline forms			
Prioritize information needs			
Conduct Surveys			
Collect and analyze survey information			
Report initial results			

7.3.2.4 Information Flow Diagrams

Once a project knows who needs what specific information and where that information is located, another tool can be utilized for the next phase of the information planning process. This tool is the information flow diagram. The purpose of the diagram is to specify how information is transmitted or circulated among staff members and to and from external organizations.

Multiple diagrams may be needed to adequately document a comprehensive plan. A master information flowchart may document information flow to, from and across major stakeholders or areas as well as document the process by which information is reported to external entities (e.g., donors and local governments). Supplemental plans may document the flow of information within departments or areas or may document information flow for a specific process such as DME-IS reporting.

Note that information does not just flow down through a hierarchical management structure. Information also flows upward from the rank and file and across organizations. For example, a health program director may be the person responsible for submitting quarterly expenditure reports to a donor agency. The information necessary to complete the report may originate in the main office (an example of horizontal information flow). In another example, project managers may be responsible for reporting beneficiary data to the program managers (an example of vertical information flow where the

information flows upward through the management structure).

The project can utilize information flow diagrams to depict how information currently flows within the project and how information should flow to achieve greater efficiency and improved accuracy in reporting. Information flow diagrams can readily indicate information bottlenecks and suggest alternative channels to alleviate these problems.

A diagram depicting an example of the method in which DME-IS information flows from its original source(s) to its intended users.

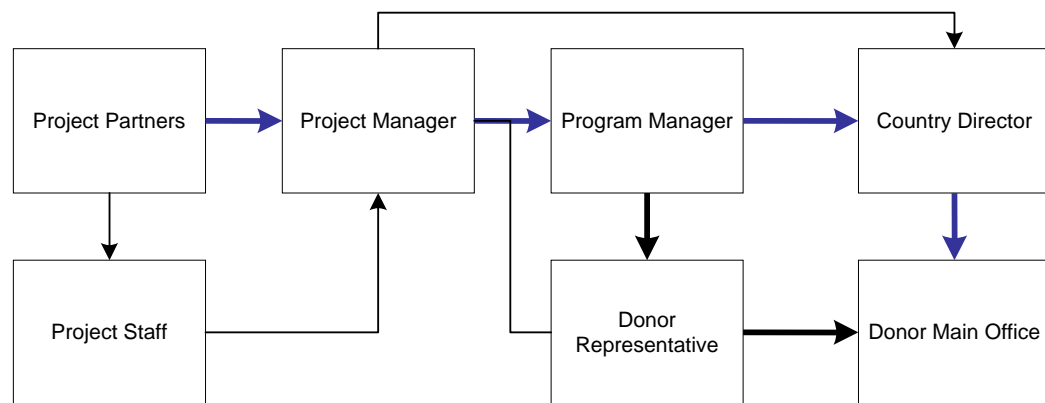

Figure 37 Sample DME-IS Information Flow Chart

7.4 Information Analysis

A project can implement a variety of plans to ensure that reported information is complete and accurate. These plans can be divided into two broad types:

- Procedures for editing, testing and analyzing that are incorporated into day-to-day operations
- Procedures for editing, testing and analyzing that are designed to be used for specific reporting purposes and that are implemented on or near the time the project is required to report the data

Generally, the more verification that can be incorporated into a project's regular data-generating activities, the better data the project is likely to produce. Project information is accessed by various users on a

regular basis for decision making purposes. Users should have confidence that a project's database is as correct and complete as it can be at any time the user needs the information.

Another reason to incorporate editing and analysis into everyday activities is that it is much easier and more efficient to identify and correct mistakes on a current basis rather than on an historical basis. Furthermore, most projects will find handling large information delivery projects easier if the information is collected and reviewed on a regular basis rather than all at once before the reporting deadline.

Analysis refers to the ability to break down the information into its component parts so that its elements may be understood. This may include the identification of the parts, analysis of the relationships between parts, and recognition of the organizational principles involved. Analysis usually involves the search for potential problems in a project, the design of solutions and the implementation of the best option. Stakeholders have many different needs for information, analysis is usually done to see if the project is doing the right activities to accomplish the desired objectives in the time and budget assigned. If there are deviations from the original plan, management needs to develop alternative solutions or remedies to make up for the delays or shortcomings.

The way information is presented helps the analysis of the information, rather than presenting all the facts the projects needs to understand the type of analysis and uses of the information and make changes or develop formats to present the information that facilitates its analysis. In most cases the representation of information in the form of charts, graphs or maps facilitates its presentation, the visualization of information also helps identify trends or changes that are not easily identified when the information is presented in tabular format

When looking at the information ask the following:

- Are there any similarities in trends from two different sets of data?
- How far or how close are we from our original objectives?
- Do we need to rethink our original assumptions on the project strategies?
- Is the information telling us something else?
- Is the information showing us what we expected to see?
- Are there any other needs to have more detailed analysis or additional information to help clarify an issue?

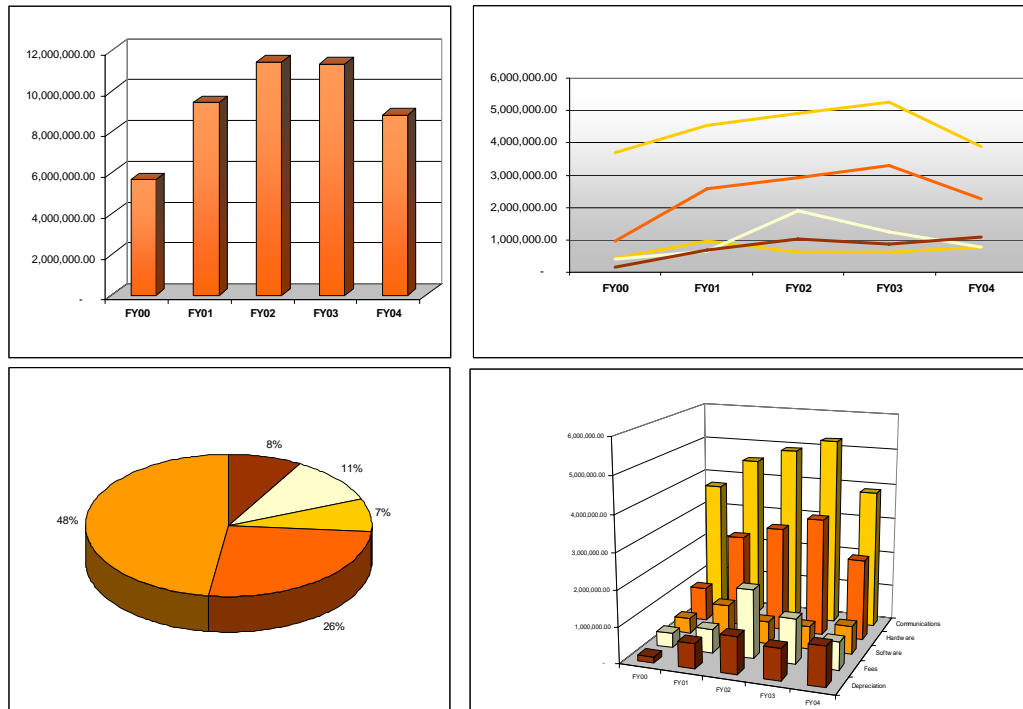

Figure 38 Sample of graphical representation of data

7.5 Reporting Information

The most visible part of a project DME information system is the reported information. Project staff, outside organizations and the donor form opinions and make decisions based on the information reported by the project. A project therefore should strive for timely, comprehensive and understandable reporting mechanisms and formats.

For project reporting, the most critical elements may be timing, accuracy and completeness. Day-to-day operations depend upon a regular flow of reliable information. The financial manager may need a monthly analysis of cash balances and projected cash flows to make cash management decisions. Program managers need reports comparing expenditures to budgets so that budgets are not overspent. A project should spend time training its staff to read project reports and documents necessary to perform their jobs.

As timeliness, accuracy and completeness are as important reporting, the format or manner in which information is presented is also critical. The format may be determined by an outside agency (for example, the

reporting formats required by the Donor). In this case, a project must take pains to report in the required manner. Reporting in the manner prescribed may involve activities such as programming changes, staff training and/or technology changes.

For external reporting with no mandated format, a project's primary consideration should be what information it desires to convey and to what audience it is presenting the information. For example, a presentation to beneficiaries about a project's progress may be less technical in nature than a similar presentation to donors.

7.6 Historical Information

An integral but frequently forgotten component of an information management plan is the maintenance of historical records. Historical information for projects is generally classified into two categories:

- Records the project is required to maintain based on the Donor or Local Government requirements.
- Records the project is not legally required to maintain but that have programmatic significance for CARE

Each project must make its own determination about what records have programmatic significance and for how long they maintain such significance. For example, a project may make multiple copies of some documents to allow for easy access to or wide distribution of information. Generally, the original document should be retained for the required period, but copies can be destroyed at the project's discretion.

After the project has specified the contents and location of the records that must be maintained due to legal requirements, it should be easier to specify the other types of records that should be retained for programmatic purposes.

Incorporating historical records management into the information management plan enables a project to:

- Know what records it has and where they are located
- Properly identify and store records that must legally be maintained either permanently or for a specified period of time
- Know when it can legally destroy records to minimize record storage issues.

7.7 Access to Information

A crucial aspect of information management for any development organization involves access to information. A project should consider:

- What safeguards are needed to limit information access to staff with proper authority to access the information?
- How are staff to access the information they need?
- What must happen when a staff member changes positions or leaves the project?
- How can the project guarantee protection for records that are deemed confidential?
- What procedures should be established to ensure compliance with the local government legal requirements?

A project must decide what types of project information will have limited access. Access may be limited because of legal requirements or internal requirements. For example, a project may not want anyone other than management staff to have access to monthly financial reports until the finance unit has reconciled and reviewed the reports, disclosure is not the issue, but the prevention of unnecessary confusion that could be caused by access to un-reconciled information.

Once a project knows what information should be classified as having limited access and what staff must have access to the restricted information, the project can determine what kinds of limitations are appropriate for the various categories of information. Access can be limited by the information's physical location or by some other types of controlled access measures. For example, classified beneficiary information may be stored in locked file cabinets in a room that has limited access or the information may be recorded on a computer that has password security.

Whatever methods are used to limit access, authorized staff must be given the tools necessary to gain access. Ensuring access may be as simple as providing keys to a room or file cabinet or assigning passwords and levels for computer access.

When a staff member moves from one position to another or when a staff member leaves the employment of the project, security changes may be necessary. For example, security codes may be changed or the staff member's computer passwords may be deleted.

Projects frequently receive requests for information from the public. However, projects may have records that are protected from disclosure. Project staff should be trained to know what information falls within this category and how to handle requests for all information, whether confidential or not.

7.8 Personnel

Human resources are a vital component of an information management system. The information management plan should:

- Assign duties and responsibilities to specific staff members or positions for creating, maintaining, reporting and/or storing designated types of information
- Establish methods for ensuring that personnel are qualified and adequately trained for the responsibilities assigned to them

7.8.1 Coordination of Responsibilities

There are a variety of tools to help a project assign responsibilities and to coordinate the assignments. Organizational charts, PERT charts and information flow diagrams are examples of tools that can be used to coordinate and assign responsibilities and to assist staff in understanding their roles in the system. For more information about PERT charts and information flow diagrams, see the Information Collection section of this chapter.

It is important that all staff members clearly understand their roles in creating, collecting, maintaining or reporting information. Job descriptions should include principle duties relating to management of information. Staff members should understand the interrelationships of their duties and responsibilities with other staff members so that they understand the consequences of missing deadlines and of not sharing information in a timely manner.

For example, a project's DME-IS coordinator is responsible for collecting and integrating all of the various records required for a Donor submission. The DME-IS coordinator usually is not responsible for maintaining the database(s) from which this information is extracted (e.g., beneficiary attendance is usually main-

tained by field personnel while budget information is usually maintained by the main office or the finance department). To ensure that the Donor submissions will occur as efficiently as possible, staff members should clearly understand their roles and how they relate to the process.

The charts and diagrams described earlier can also help identify staffing patterns that may require change to allow for meeting deadlines or to provide continuity during times of staff reorganization, staff turnover or the absence of key staff. For example, if there is one staff member responsible for project's reporting, overseeing the midterm evaluation and serving as the DME-IS coordinator, creation of a PERT chart may demonstrate that critical deadlines cannot be met without a reassignment of some duties to another staff member. Or, if a key staff member resigns, organizational charts and information flow diagrams can provide important information to help a new staff member understand the position requirements and workload fluctuations.

Other information sources that may be helpful when a project is trying to assign and coordinate information responsibilities are:

- Well-written job descriptions
- Records showing individual staff members' skills and prior work experiences

7.8.2 Staff Qualifications and Training

Even with the best information management plan, if the staff members assigned to carry out the plan are not qualified or are not adequately trained, the plan can fail. For example, a project staff responsible for submitting quarterly reports to the project manager may be completing the report mechanically without understanding why certain information is reported in a certain way. If something unusual occurs, reports may be completed incorrectly or not completed at all. For example, if a Donor contract adjustments are made that affect a prior report, a corrected report may be required. If the staff does not understand how the adjustments affect the Donor report, the corrected report may not be completed.

A project should identify critical qualifications appropriate to each position and hire people based on these qualifications. Qualifications may include:

- A specific degree or level of education
- A professional certification or specialized training
- Certain types of previous job experience
- Combination of the above

Most employees, even though they meet specified qualifications, require training in a specific job. Training may relate to diverse areas including:

- Computer hardware
- Special equipment
- Software programs
- Specific processes required in the position
- How to read special reports
- How to fill out special forms

Appropriate training can come from a variety of sources, local education service centers, professional organizations, non-profit organizations and private vendors offer training in many areas on either a regular basis or on an as-needed basis. In addition, projects should consider whether existing staff members may be able to provide in-house training for other staff members.

Training should be considered an on-going process. Frequently, changes in process, donor requirements, technology, rules or regulations require additional training of experienced staff.

7.9 Technology

Information technology is significantly changing the development environment. In recent years, rapid advances in hardware, software, and communications technologies have yielded increases in productivity and effectiveness for office personnel, particularly in the areas of information collection and reporting.

Depending on the size of the Project, using technology to speed up the information management process may be useful. Using technology is not an end to itself but a tool to help the automati-

zation of a well designed process. The use of technology can assist in the data capture and storage and distribution of information to all stakeholders, but the analysis remains in the hands of the people involved in the project.

Selecting the right technology for the right job is not an easy task. The projects needs to evaluate the right “doses” of technology that will help the project. Too much technology can actually hinder the project’s ability to operate efficiently and instead of working with technology the project ends up working for technology.

Computers are efficient in managing large amounts of data and producing reports, and can help DME by organizing the information and presenting the results quickly for the project to make decisions.

Deciding to use technology to automate the DME-IS process should not be done until the manual system is up and running. If the manual system is not working then technology will not help at all, on the contrary it may add more problems and staff may feel the culprit is the technology and not the process.

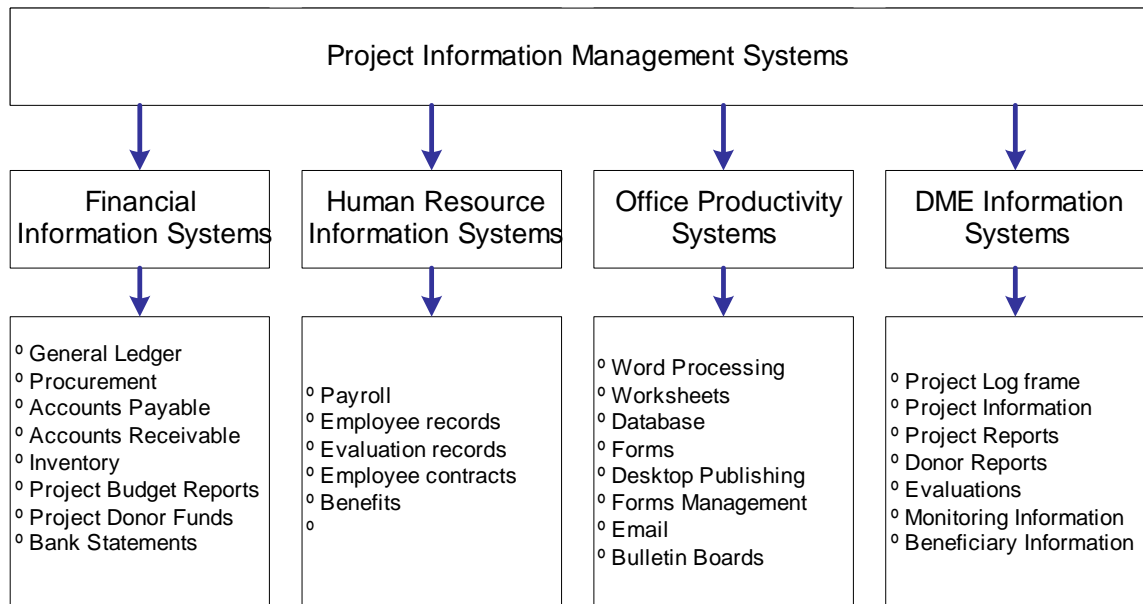

Figure 39 Project MIS Applications

7.9.1 Deciding to Computerize DME-IS

The size and complexity of the project will define the level of technology that can be implemented. Use of technology is not a necessary element at all levels of the project. The use of computers can assist in the organization of information but at the end is the project staff who are in charge of the analysis and use of the information processed by technology. When deciding to computerize the DME-IS take in consideration the following questions:

- Do all project staff and partners have adequate skills to use computers? If not then how much it will take to train staff to the desired level?
- What are the manual processes that technology will help the project? If the process is simple then a complex database system may not be needed at all.
- Do all project locations have good access to technical support, what would be the cost of the support to maintain and fix the computers?

The purpose of having a computerized DME-IS is to facilitate and expedite the handling of large amounts of information. Before the project decides to computerize DME-IS a manual system should be in place and should be functioning. The computer will not be of any help if the manual system is not working, if project staff are not using the manual system then adding technology will not help.

7.9.4 Technology Related Issues

Although the use of technology can have significant advantages to a project DME-IS, it should not be viewed as a one-stop solution or a way to solve other non-technical related problems. The project needs to make a careful consideration on the type and complexity of its information management needs to decide the level and complexity of its technology solutions. It can be quite easy for project to go an develop a complex system without first understanding its own realities about using and supporting the technology.

When making technology-related decisions, the following activities should be conducted:

- Perform a cost/benefit analysis of the technology

- Identify the level of resources available to the project for technology (both monetary and human resources)
- Review the types of technology or technological services available to meet the needs of the project
- Seek best practices from other comparable projects

Human resources are required to successfully maintain information systems. Obviously, programming and technical resources are required to install the hardware and software. However, a system is only as effective as the people who use it. Accurate work-flow design, development of policies and procedures and adequate training are vital for a successful implementation. Some key elements to remember are:

- Do not automate an existing work flow without reviewing other alternatives. Often, the implementation of a new system provides an opportunity to evaluate and modify processes, policies and procedures.
- Get input from the eventual end users of the system during the design or package selection phase of the project. This step is beneficial for several reasons. First, people generally fear change; it is important for end users to feel involved in the process to make change happen. Second, informal work patterns develop over time. Recognize that they exist and incorporate them into the new system.
- Develop detailed technical and user documentation, including work-flow policies and procedures. Information systems generally have a life-span of five years. Because the information is an on-going process, user documentation and on-going training is important because of new hires and staff turnover.
- Train staff as close to implementation as possible; people tend to forget systems training if it is done too much in advance of their actually working on the system.

7.10 Internal Controls

As a project writes an information management plan, inherent in the process should be consideration of internal controls. Each project should have an internal control structure in place to pro-

vide reasonable assurance that the project's assets are safeguarded from unauthorized use or disposition.

The attitude of a project's administration about the importance of internal controls is a key factor in the successful implementation of an internal control system. Development of policies and procedures that include internal control elements is critical. Willingness to immediately take corrective action when deficiencies are discovered is also important.

When a project creates an internal control plan, it should consider including:

- Security measures to safeguard the project's assets from internal or external misuse (such as video monitoring, limiting access, security codes and computer passwords)
- Segregation of duties
- Hardware and software controls
- Internal audit and review functions
- External audits

7.11 Implementation Strategies

Information is an important resource for projects, the organization and donors, with information quality influencing decision quality, it highlights our need to manage our information as a resource. Information Management has as its goal the management of information as a resource, but that has not been given the required level of priority. Problems with the implementation of Information Management are indicated by the presence of redundant or inconsistent information, inability to share information across systems, and difficulty finding the information on systems.

Most of these difficulties are related to behaviors linked to perceived ownership of information by organizational sub-units. To improve the management of information we recommend that country offices take ownership of the information resource at the executive level, and educate users of the information on the benefits of stewardship of the information they use. This will en-

courage staff at all levels to see information as a resource, not merely a cost of doing business.

7.12 Monitoring the DME-IS

7.12.1 Monitoring Information Quality

Every Project DME-IS should establish and information quality as a performance goal. Quality includes the utility, objectivity, and integrity of the information. The level of quality should be "appropriate to the nature and timeliness of the information to be disseminated" and will be affected by the nature of the information collected by the project. In considering utility, projects should evaluate the usefulness of particular information to those expected to use it.

The goal of information quality management is not about improving what is in the information repository or even the databases. The goal of information quality management is: To increase project effectiveness by eliminating the costs of non-quality information and increasing the value of high quality information assets. Information quality must concentrate on the people responsible for collecting, analyzing and disseminating information and not on the system. After all it is people who manage and use information.

Essential ingredients for information quality management:

- Understand that information quality is a project problem, not just a systems problem, and solve it from a process perspective.
- Focus on the users and sources of information, not just the information.
- Implement reviews of information quality in the project process
- Measure not only validity but accuracy.
- Evaluate the impact of poor quality information on the project and donors expectations.
- Provide quality training to staff in charge of collecting information.
- Manage quality as a product to the various projects stakeholders.
- The quality of decisions has a direct correlation with the quality of the information provided.

Information should be fit for its purpose, timely and accurate: it must be available to the staff that needs it at the right time in an appropriate format. In order for information to be of value, it must be quality information of direct relevance to the projects objectives. Inaccurate, partial or superfluous information is of no value and may even be detrimental to the overall project processes. The quality of information can be evaluated via the use of information needs analysis and quality metrics.

Some principles and good practice Related to quality of monitoring information. When you have poor results with any of the following items, here are some possible causes and relevant principles/practices:

Item	Possible Causes	Relevant Principles or Practices
Accuracy of information	<ul style="list-style-type: none"> ✘ Exaggeration, upwards or downwards, by beneficiaries or stakeholders ✘ Poor methods for information collection ✘ "Conversational" info gathering 	<ul style="list-style-type: none"> ▶ Trust building with beneficiaries ▶ Involvement of beneficiaries in design of M&E system ▶ Careful selection of methods ▶ An M&E plan for staff to collect information
Completeness of information	<ul style="list-style-type: none"> ✘ Competency of information gatherer in administering information collection technique ✘ Different methods and/or styles used by different enumerators ✘ Poor quality record keeping by stakeholders or partners ✘ Not enough staff to cover entire region ✘ Monitoring not a shared responsibility ✘ Poor sampling techniques 	<ul style="list-style-type: none"> ▶ Training and coaching of staff in information collection and sampling, inc. refresher training ▶ Clear identification of methods and communication styles ▶ Involvement of stakeholders in M&E planning ▶ Estimation of M&E resources for project budget ▶ M&E planning to assign roles in M&E ▶ A resource person in CO, MERMU, or external to do quality check, if staff capacity is not adequate
Excessive information	<ul style="list-style-type: none"> ✘ No link between information collection and project indicators ✘ No clear understanding of purpose of information 	<ul style="list-style-type: none"> ▶ M&E planning at project start up, linking information needs with indicators ▶ Involvement of project stakeholders in M&E planning
Representativeness of information	<ul style="list-style-type: none"> ✘ Survey instrument ✘ Sampling technique ✘ Beneficiary or respondent availability and/or cooperation ✘ Information collector bias 	<ul style="list-style-type: none"> ▶ see above
Means of measurement used at field level	<ul style="list-style-type: none"> ✘ Inaccurate measuring device, method, or estimation done by beneficiaries or local field staff ✘ Different measures by different beneficiaries 	<ul style="list-style-type: none"> ▶ Coordination with the field on use of measuring techniques ▶ Spot checking with beneficiaries (rather than relying

Item	Possible Causes	Relevant Principles or Practices
Quality of information recording	<ul style="list-style-type: none"> ✘ No sense of ownership by stakeholders in recording information ✘ Stakeholders have no appreciation for value of information recording ✘ Not enough resources ✘ No standardized forms 	<p>only on key sources of info)</p> <ul style="list-style-type: none"> ▶ Involvement of stakeholders in M&E planning ▶ Estimation of M&E resource requirements for project budget ▶ Prior design of standardized forms and review with stakeholders ▶ Training of stakeholders in use of forms ▶ Evaluation and follow-up of training
Use of indicators	<ul style="list-style-type: none"> ✘ Poorly used or no use of indicators for information gatherers and/or beneficiaries who did not participate in their selection ✘ Indicators formulated by external consultant prior to proposal submission 	<ul style="list-style-type: none"> ▶ M&E planning at project start-up to review indicators with stakeholders ▶ For a participatory project design, allowing the development of two levels of indicators, one at beneficiary level
Validity of indicators	<ul style="list-style-type: none"> ✘ Indicators not a good measure of the goals to be achieved ✘ No review done of indicators to check for reliability, validity at project start 	See above
Adequacy of means of verification	<ul style="list-style-type: none"> ✘ Cross-checking and triangulation not being done – lack of staff skill, poor planning, lack of appreciation for cross-checking ✘ Only one method or one source being used for information collection 	<ul style="list-style-type: none"> ▶ Training and coaching of staff, inc. refresher training
Motivation of information gatherers or sources of info	<ul style="list-style-type: none"> ✘ Lack of trust by sources of info ✘ No sense of ownership by information gatherers in information ✘ No participation of information collectors in analysis ✘ Information gathering perceived as an add-on reporting requirement; implementation considered more important 	<ul style="list-style-type: none"> ▶ Trust building with beneficiaries ▶ Involvement of staff in M&E planning ▶ Involvement of staff (information collectors) in analysis ▶ Intermittent opportunities for reflection among project team ▶ Estimation of M&E resource requirements for project budget ▶ Sharing of results with all levels of project
Skill level of information gatherers or sources of info	<ul style="list-style-type: none"> ✘ Poor quality, inadequate, or no training given ✘ No understanding of the purpose of the information/information ✘ Insufficient importance attached to quality monitoring by project management 	<ul style="list-style-type: none"> ▶ Proper training with adequate timeline at project start ▶ Involvement of all stakeholders in M&E planning ▶ CO organizational culture that emphasizes quality DME and impact
Bias of information gatherers	<ul style="list-style-type: none"> ✘ Belongs to community and fears local power structure ✘ Belongs to local culture and does not see own biases ✘ External to culture and has pre- 	<ul style="list-style-type: none"> ▶ Design of information collection methods to minimize potential for bias ▶ Systematic check for researcher bias when informa-

Item	Possible Causes	Relevant Principles or Practices
	<ul style="list-style-type: none"> conceived views ✘ No proper check of information/info collected for researcher bias 	<ul style="list-style-type: none"> tion is received ▶ Recruitment procedures for enumerators that checks for any apparent biases
Appropriateness of method(s)	<ul style="list-style-type: none"> ✘ Methods chosen based on staff experience, not only assessment of methods ✘ Staff preference of quantitative vs. qualitative ✘ Inappropriate to culture resulting in resistance, poor quality answers, etc. 	<ul style="list-style-type: none"> ▶ Exposure of staff to qualitative and quantitative methods ▶ Proper training of staff, once methods are identified ▶ Criteria for selection of best methods, inc. socio-cultural
Quality of information instruments	<ul style="list-style-type: none"> ✘ Time constraints in proper design of instruments ✘ No pre-testing of instruments ✘ No reflection and check with information gatherers ✘ Poorly worded questions ✘ No clarity in the broader questions being posed by project 	<ul style="list-style-type: none"> ▶ Realistic planning of start-up activities ▶ Pre-testing of survey instruments ▶ Ample opportunities to involve information gatherers in reflecting on information/info ▶ Quality check of information instruments ▶ Link instruments to indicators and precise information needs (part of M&E planning)
Quality control of information collected	<ul style="list-style-type: none"> ✘ Time constraints ✘ No one assigned this role ✘ Over confidence of staff in quality ✘ Lack of skill in what to look for 	<ul style="list-style-type: none"> ▶ Realistic planning ▶ A conscious effort to assign responsibility for quality control to competent person ▶ Staff training and learning lessons (from failures and duplicative effort)
Rumor and/or anecdotal info vs. facts	<ul style="list-style-type: none"> ✘ A lackadaisical attitude towards information collection ✘ Entrenched work habits that accept poor quality ✘ Easier to rely on rumor or anecdotes ✘ Inability to distinguish between rumor and fact 	<ul style="list-style-type: none"> ▶ Staff performance reviews ▶ Involvement of staff in M&E planning ▶ Project management focus on quality ▶ Scrutiny of consistently, highly favorable assessments from staff ▶ Citing source of info
Information interpretation	<ul style="list-style-type: none"> ✘ Use of qualitative methods with little experience in the synthesis of the information ✘ Left up to one person (information entry person) who did not participate in the collection ✘ Poor coding 	<ul style="list-style-type: none"> ▶ Training of staff in use of qualitative methods (esp. focus group discussions) ▶ Team work on information compilation and review ▶ Multiple quality check mechanisms between preparation for fieldwork and information entry

DME Workshop Handout. Produced by Mary Picard, DME Advisor, MERMU

7.12.2 Monitoring and Evaluation System Plan

A monitoring and evaluation plan should be included as a part of project information management plan design. Project activities should be scheduled on annual implementation or work plans.

Monitoring Planning Matrix				
Goal Hierarchy	Selected Effect Indicators	Outputs	Activities	Inputs
Indicators	A subset of evaluation effect-level indicators which are easily monitored	Output-level indicators	Activity-level indicators	Input-level indicators (link to financial accounting)
Information Needed	Specific variables to measure for each selected effect indicator	Specific variables to measure for each output indicator	Specific variables to measure for each activity indicator	Specific variables to measure for each input indicator
Information Source & Collection Method	Same as in evaluation matrix for specific effect indicators	Based primarily on project records, but may require periodic survey	Based primarily on project records	Based primarily on project records, financial accounts, and records
Frequency of Collection	Annually or other regular/periodic timeframe	Specify the time-frame needed for efficient monitoring	Specify the time-frame needed for efficient monitoring	Specify the time-frame needed for efficient monitoring
Person Responsible	Who will be responsible for collecting the information	Who will be responsible for collecting the information	Who will be responsible for collecting the information	Who will be responsible for collecting the information
Information Analysis	Primarily trend analysis to measure effect-level changes over time	Trend analysis and simple statistics	Basic statistics and accounting	Goods and services expenditure accounting
Reports and Use of Information	Used as early warning of effect changes; develop key questions	Project tracking and linkage to goal-level changes	Project tracking and accountability	Accountability and budgeting

From MER guidelines

7.13 Evaluating and Improving DME-IS

Just like any development project the DME-IS needs to be evaluated and improved. Look at the processes, use the findings from the evaluations and lessons learned to help understand what needs to be improved and why.

Build in the information plan activities designed to evaluate and improve the information management process that supports DME-IS. Assign timelines, responsibilities, a budget to accomplish the above. Get the project staff and stakeholders in the process of evaluating, if possible get some outside expertise to help in the evaluation.

The IM plan will be more complete when an element exist that incorporates the lesson learned into the new cycle or the next time a projects will design its DME-IS.

7.14 Information Audits

An information audit is a systematic process through which an organization can understand its knowledge and information needs, what it knows, the information flows and gaps. Resulting from an information audit is an 'information map' which can be used as the basis for designing the foundation of a corporate information strategy or a knowledge management strategy.

7.14.1 what will an information audit do?

An information audit will review what information is created and needed across the organization. Everyone within an organization has a role in creating and using information – even if they do not realize it! One of the positive side effects of a well-run information audit is that it raises the awareness across the organization of the value of information and the value of sharing knowledge. An information audit will also:

- Identify the information needs of the organization itself, the various business units and divisions, and the specific needs of individuals
- Identify the information created and assess its value to the organization
- Identify expertise and knowledge assets and enable the start of an intellectual asset register
- Identify the information gaps
- Identify quick wins that could be implemented to produce immediate benefits
- Review the use of external information resources and how it may be used more effectively
- Review the use of internal information resources, how valuable they are, and how they may be improved

- Map the information flows and current bottlenecks within those flows
- Develop an knowledge and information map of the organization

7.14.2 Information audit benefits

Information and knowledge are now recognized as core assets of any organization and are potentially the source of an organizations key competitive advantage. The main benefit of an information audit is the development of a much better understanding of this prize asset and how it can be used to stimulate creativity and innovation. Specifically an information audit will be to identify how the organization can:

- make better use of its intellectual assets
- make better use of external information
- avoid inefficiencies and duplication of information
- avoid information overload
- save real time and money through efficiencies

7.14.3 The information audit approach

A successful information audit must reflect the organization and how it works. It must review the different business processes within the organization, exploring what information is needed in the process and what information is generated by the process. It requires a top-down as well as a bottom up approach looking at all the information flows, barriers, and inefficiencies. An independent information audit team is often preferable, bringing confidentiality and a fresh perspective to information management practices and use. To achieve all the objectives of the information audit, to gather all the data, and to develop practical proposals, a mix of interviews, questionnaires, discussion groups and focus groups need to be used.

To understand the key issues and business processes a number of people in 'central' positions are interviewed. A detailed questionnaire to all staff draws out specific information and appropriate data. Discussion groups test conclusions, and focus groups explore particular issues and challenges. Once the information map is complete and recommendations implemented the infor-

mation audit should not be forgotten. Organizations change and information needs and flows change – the information audit should be a regular feature of an organization helping to maintain and capitalize on this vital asset.

Figure Index

Figure 1 The DME Project Cycle	17
Figure 2 The DME-IS levels.....	21
Figure 3 Efficiency of DME-IS.....	22
Figure 4. Level One	24
Figure 5. Level Two	25
Figure 6, Level Three	25
Figure 7, Level Four	26
Figure 9 Information Management Process	34
Figure 10 Graphical Logframe WBS.....	41
Figure 11 Logframe and Project Indicator's Progress	42
Figure 12 Logframe and Project Resource Reallocation	43
Figure 13 Project Indicators Improvement	43
Figure 14 Relationship between Process and Outcomes.....	44
Figure 15 Example of Country Office Program Portfolio	46
Figure 16 Country Poverty Map	47
Figure 18 Classification of Projects at Country Office Level	48
Figure 19 Funding Trends.....	49
Figure 20 Logframe Schedule.....	54
Figure 21 Project's Logframe Schedule	61
Figure 22 Project Org Chart	67
Figure 21 Project Organigraph	68
Figure 22 Project Organigraph, Networks.....	69
Figure 24 Project Budget and the Logframe Schedule	73
Figure 25 Project Budget Chart	74
Figure 26 Ethnic Groups.....	78
Figure 27 Women's Participation in Local Elections	79
Figure 28 Human Development Index 2000	79
Figure 29 Information Environment	83
Figure 30 Information Flowchart for Defining Information Needs	99
Figure 31 Project Relationships	101
Figure 33 The Information Process Life Cycle	107
Figure 34 Map of Project Information Sources	117
Figure 33 Information resources Map	118
Figure 35 Example of a Timeline of Major Events for a Project Information Needs.	164
Figure 36 Work Flow PERT Chart	165
Figure 37 GANTT chart Information Schedule	166
Figure 38 Sample DME-IS Information Flow Chart.....	168
Figure 38 Sample of graphical representation of data	170
Figure 40 Project MIS Applications.....	176

Fifty Two Good Reasons for Avoiding Project Information Systems

As part of our efforts to make life easier for overworked project directors, here are some of the more original responses to evaluation propositions. When a single reason is not enough, one can always give two or three, for example, "our project is different and the costs are too high". However, one must be careful that the two reasons given do not contradict each other, for example, "we are constantly evaluating" and "it's impossible".

1. Our project is different.
2. It would cost too much.
3. We don't have the time.
4. The project is too limited.
5. It doesn't figure in the work plan.
6. We've never done it before.
7. The donor wouldn't like it.
8. Give me the funds.
9. It's not my responsibility.
10. An Information system isn't necessary.
11. It's too theoretical an exercise.
12. Let's be realistic.
13. It's none of our business.
14. It works now, so why change it?
15. We're not ready for it yet.
16. It's not included in the budget.
17. We can well do without it.
18. We've never done this before.
19. There must be some ulterior motive.
20. Is somebody trying to teach me my job?
21. It might work in any other organization (region / country / technical domain) but it will never work here.
22. I'm not convinced that it would be useful.
23. "It's a trap!".
24. Think of all the hassle that it would cause.
25. It's impossible to do it with the necessary objectivity.
26. Change upsets things too much.
27. We've always worked like this.
28. We've done what we said we'd do.
29. We've done what was in the project document.
30. We don't have any problems.
31. There's been an organization reshuffle.
32. Financial havoc has delayed our schedule.
33. Our accounts have just been audited.
34. The donor says that it's one of his best projects.
35. It's a pilot project.
36. It's a demonstration project.
37. It's an experimental project.
38. The project is too new.
39. The project is almost over.
40. The organizational framework hasn't been worked out yet.
41. We can't find the original work plan.
42. The program specialist in charge at the beginning of the project was somebody else.
43. The donor was happy with the project.
44. The beneficiaries haven't given it's contribution yet.
45. The project isn't ready for systems yet.
46. We don't have all the skills
47. The project document is too vague.
48. It's a national holiday.
49. It's the rainy season.
50. Let the M&E/IT Unit take care of it.
51. Outsiders won't understand the complexities.
52. I have to take my annual leave

Which one is your favorite?